

 **Installationsanvisning**
Baselift Corner 6312H / 6312L

 **Installation Instructions**
Baselift Corner 6312H / 6312L

 **Montageanleitung**
Baselift Corner 6312H / 6312L

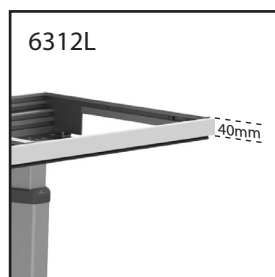
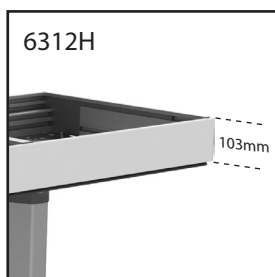
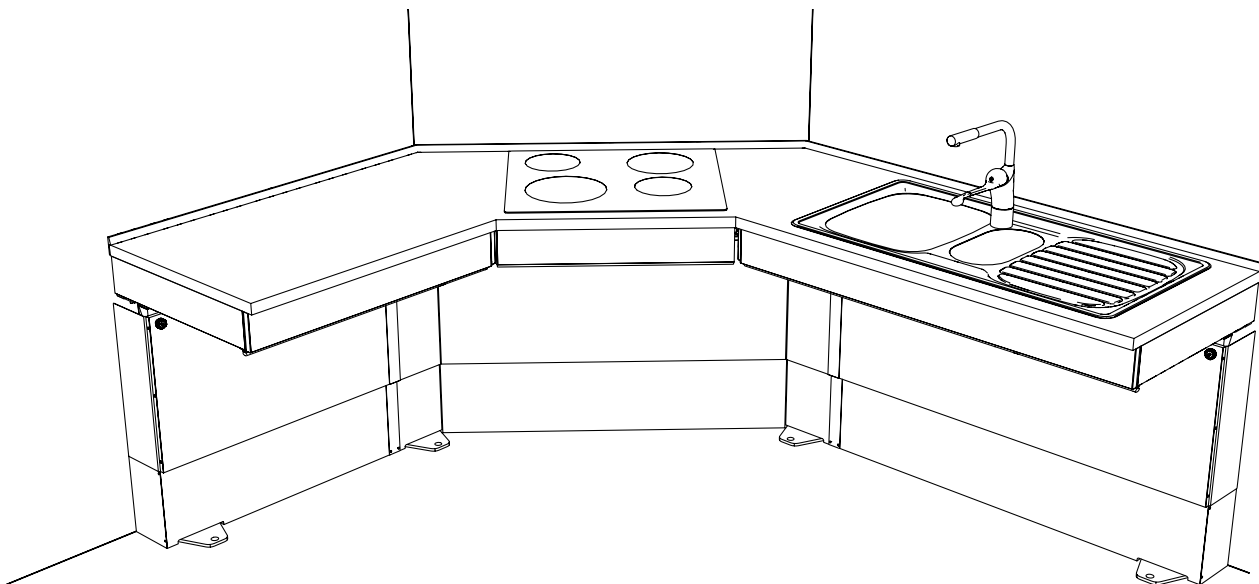

WWW: Baselift Corner 6312



Forhandler i Norge:

ASTEC AS
Kapellveien 18, 1410 Kolbotn
22 72 23 55 • astec.no



Förberedelser / Preparations / Vorwort

SE Tack för att ni har valt att installera en produkt från Granberg!

För att produkten ska fungera säkert är det ytterst viktigt att installationsanvisningen följs. Installatör skall läsa och förstå hela installationsanvisningen innan installation påbörjas. Installatören ansvarar för att golv- och väggkonstruktioner uppfyller de krav som ställs och att fästelement klarar de krafter som kan uppstå. Installatör ansvarar även för att rätt behörighet och kompetens finns för el- och vattenarbete.

Efter utförd installation ska produkten funktionstestas enligt avsnitt på s. 32.

EN Thank you for choosing to install a product from Granberg!

In order for the product to work safely and securely, it is extremely essential that the installation instructions be followed.

The installer should read and understand all the installation instructions before installation begins.

It is the installer who is responsible for floor and wall structures meeting the set requirements and that fasteners can withstand the forces that may occur.

The installer is also responsible for the right authority and skills being available for electric and water works.

After completed installation, the product shall be functionally tested according to sections on p. 32.

Vielen Dank, dass Sie sich für ein Granberg-Produkt entschieden haben!

DE Für die Sicherheit ist es wichtig, den Anweisungen in der Montageanleitung folge zu leisten.





Der Monteur muss vor der Montage die gesamte Anleitung gelesen und verstanden haben.

Der Monteur trägt die Verantwortung für die Tragfähigkeit des Bodens und der Auswahl der richtigen Befestigungsmittel, unter Berücksichtigung der auftretenden Kräfte.

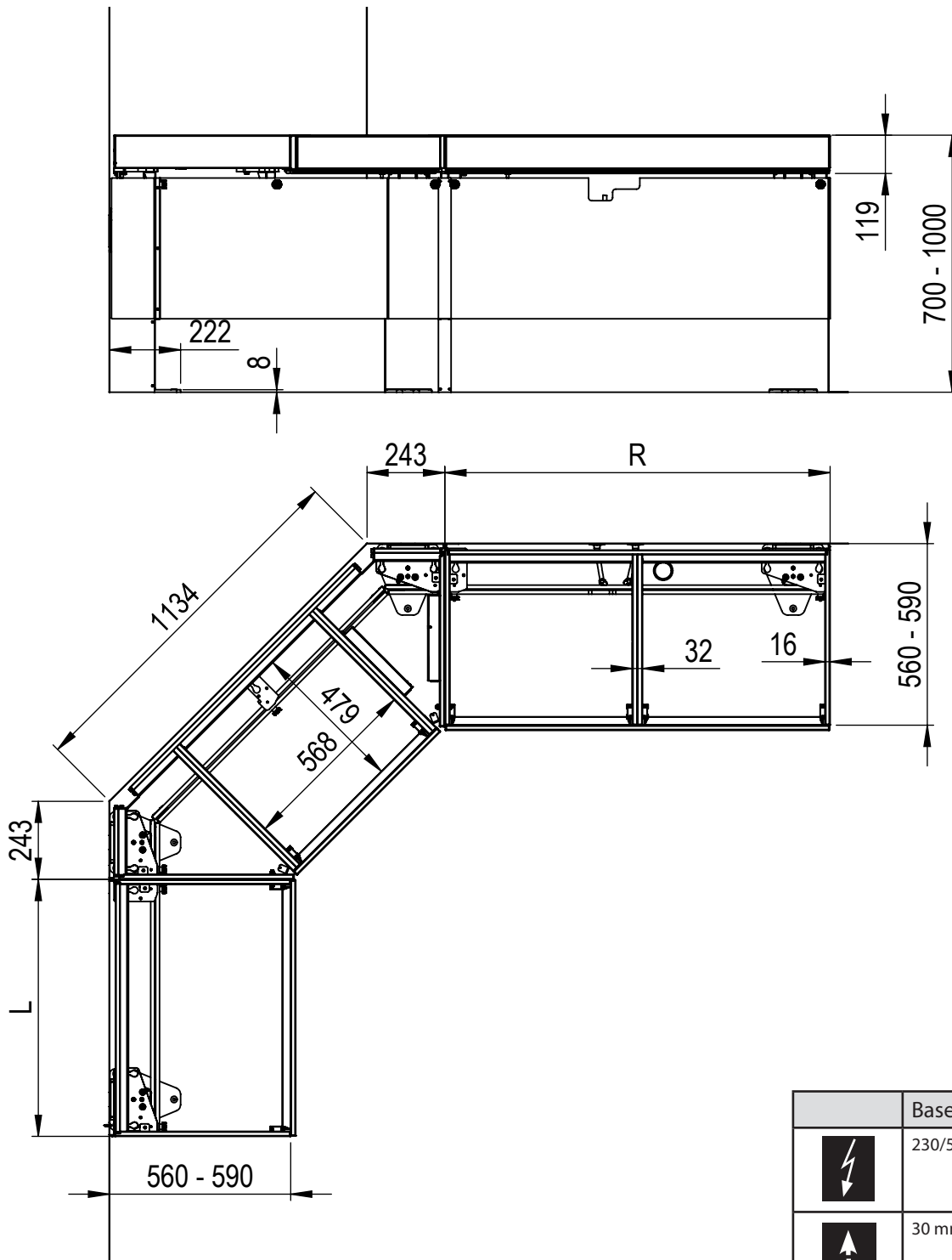
Der Monteur ist auch für die Strom- u. Wasseranschlüsse verantwortlich und muss entsprechend dafür qualifiziert sein.

Nach der Montage muss eine Funktionsprüfung gemäß der Beschreibung aus Seite 32 stattfinden.



Baselift 6312	
	230/50Hz/5.0A
	30 mm / s
	300 mm 700-1000 mm
	100 kg
	6 / 1h

Leveransinnehåll / Content of delivery / Lieferumfang

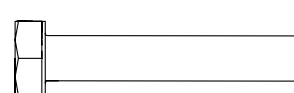
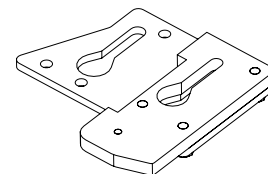
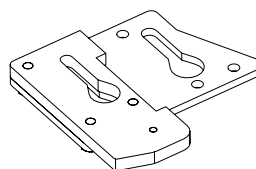
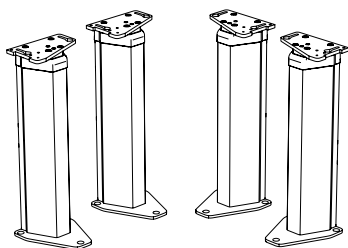
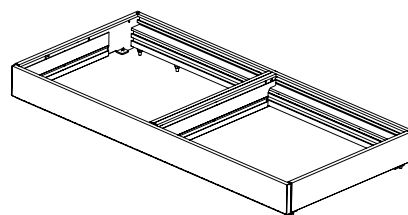
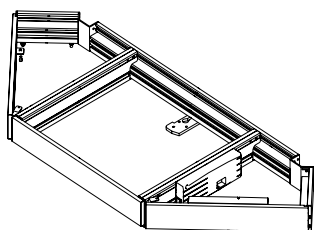
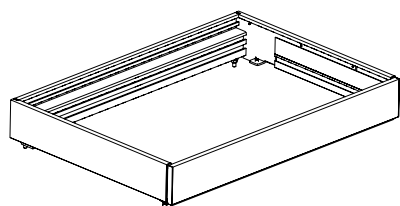

2x M8X45

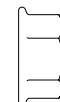

2x M8

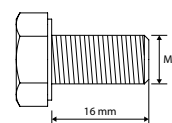
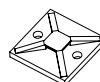

6x M8x16mm

Tillbehör / Accessories / Zubehör

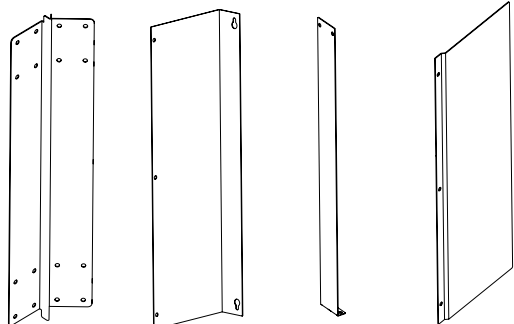

4x

6x

4x

2x

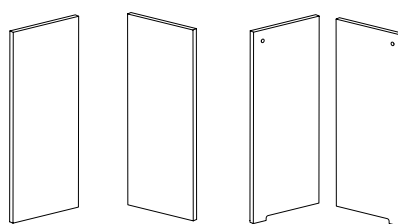

72x 3x12 mm



24x 3x16 mm



8x M6x12

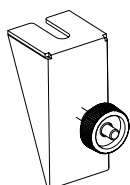

8x

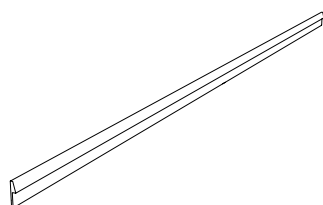

3x

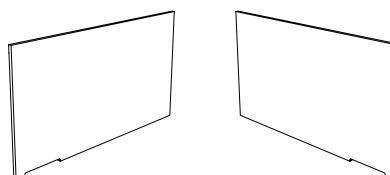
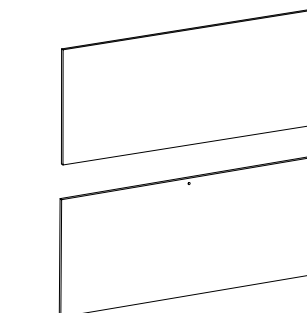

1

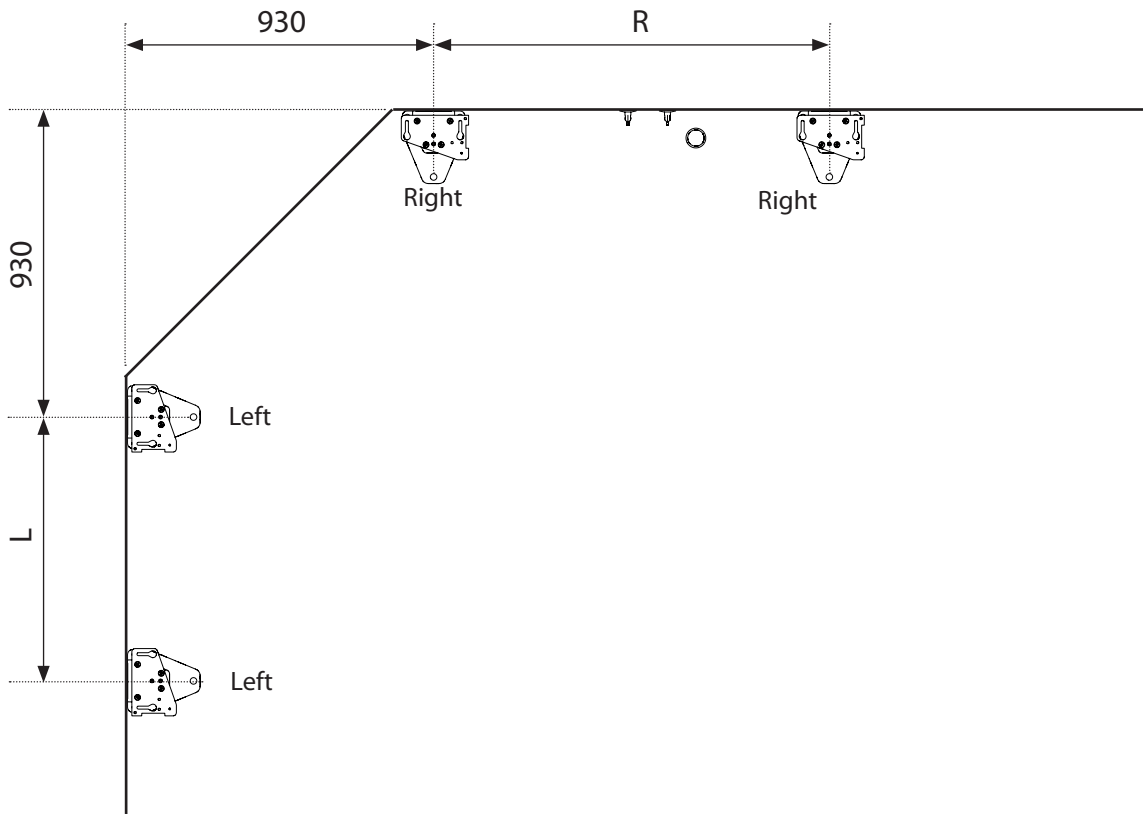
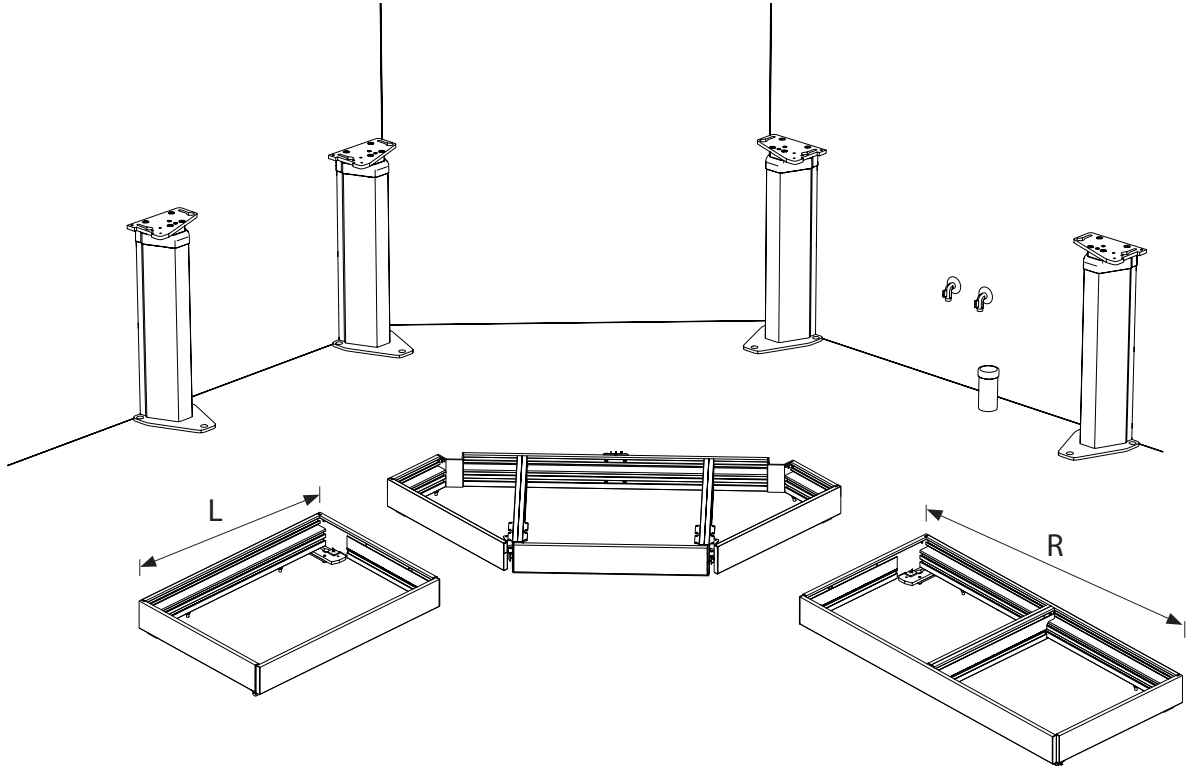
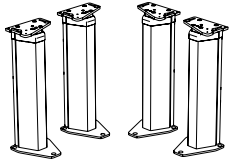

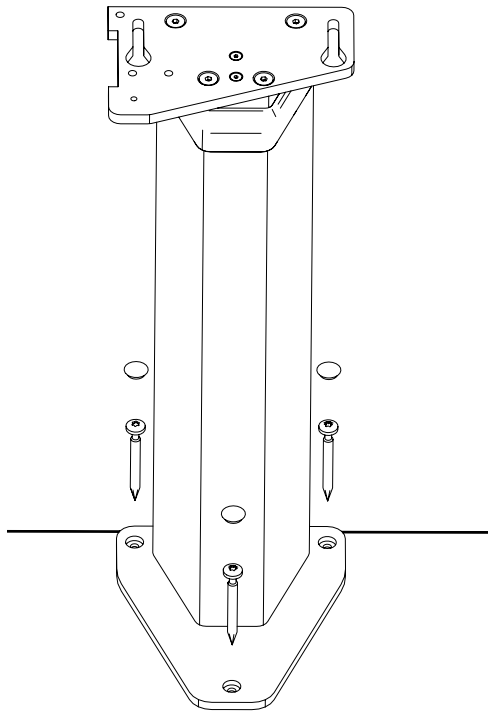
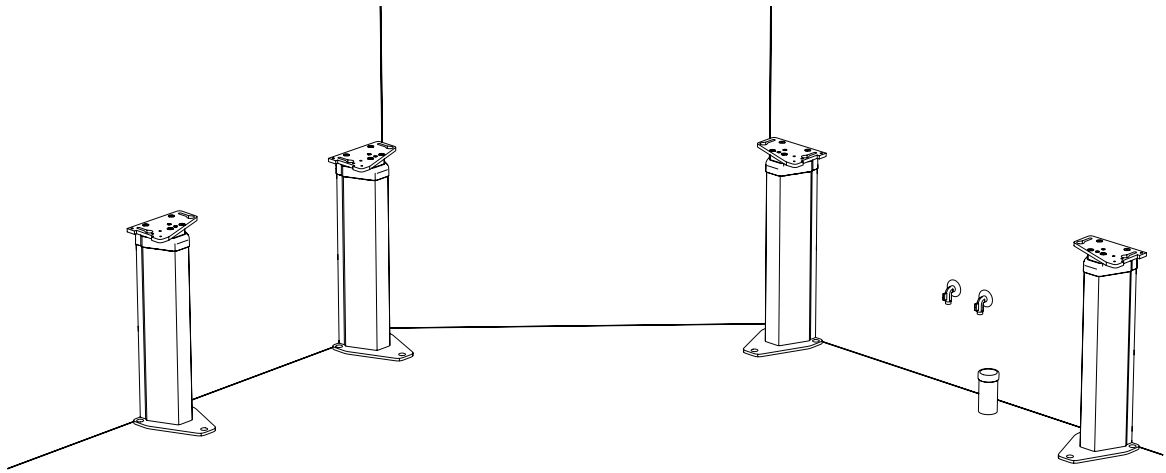

3

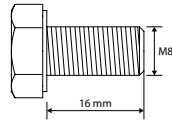
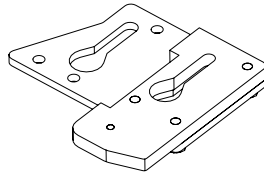
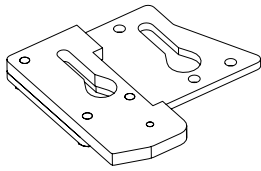

6x M8x16mm

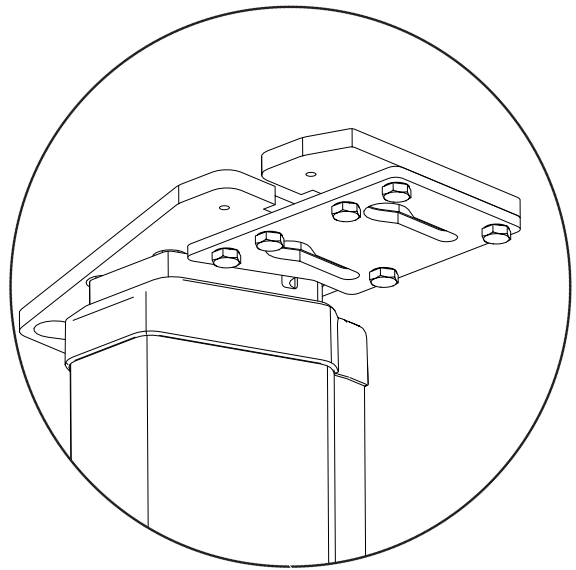
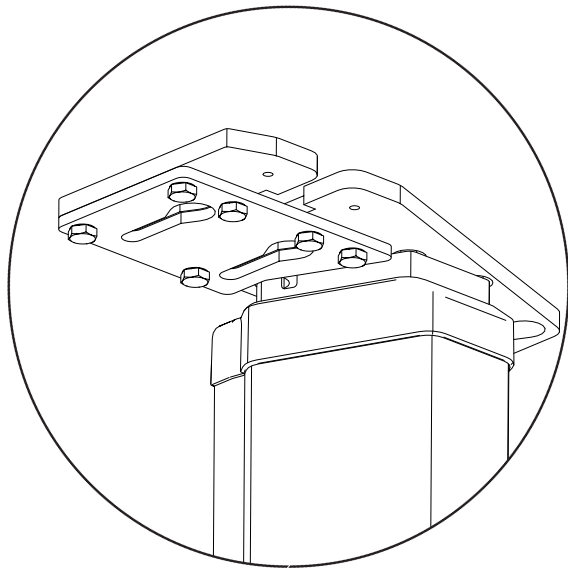
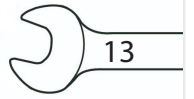

4

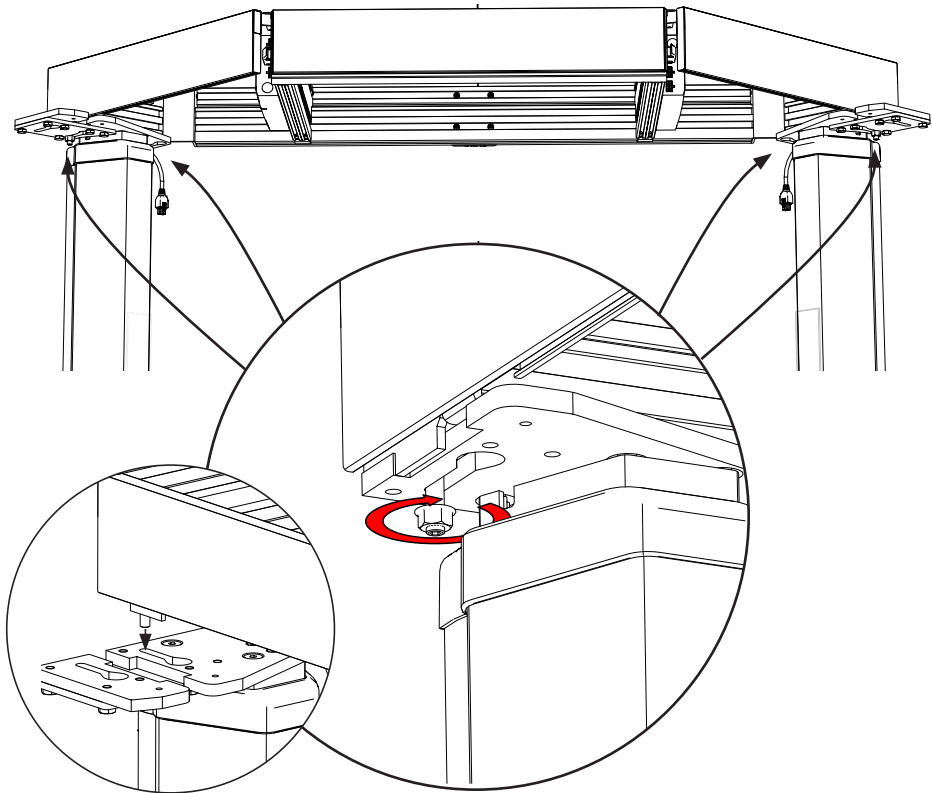
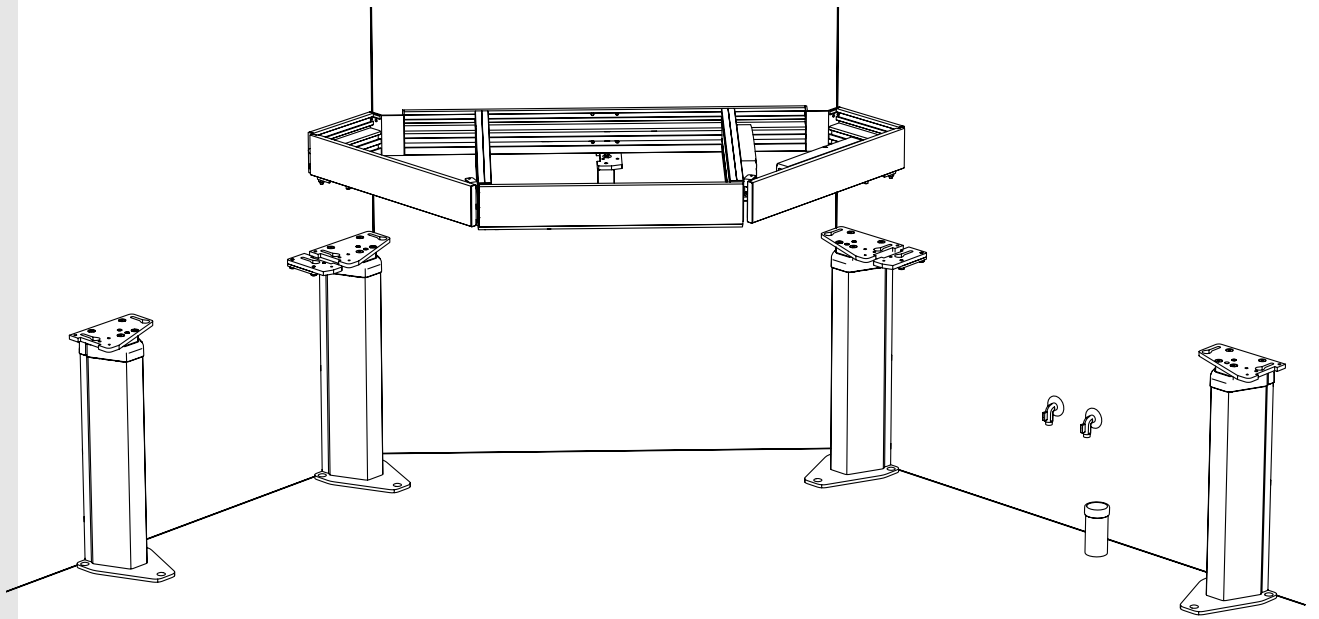
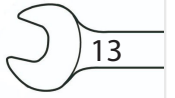
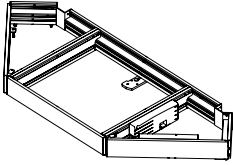

5

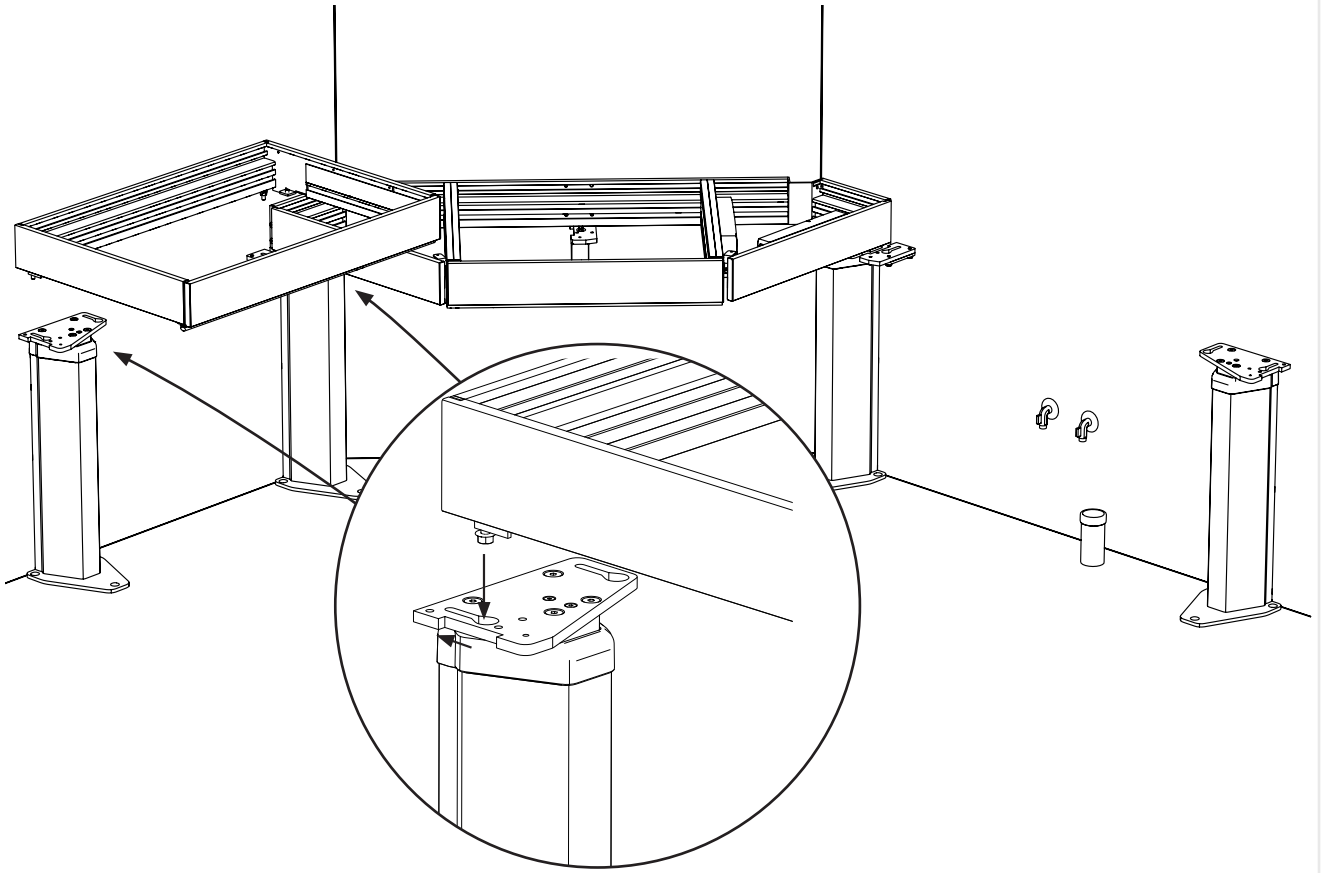
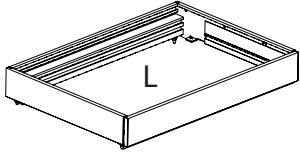

6

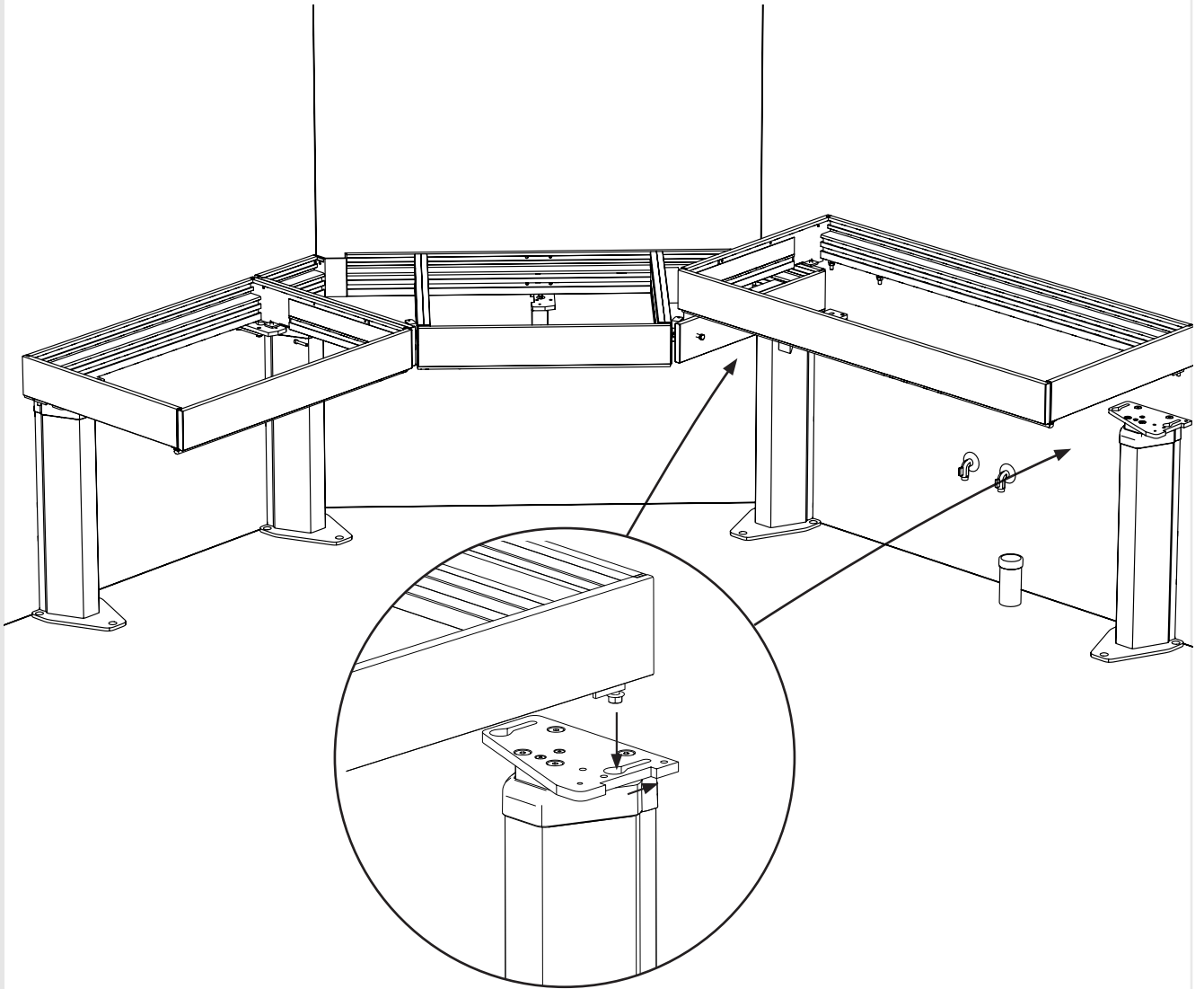
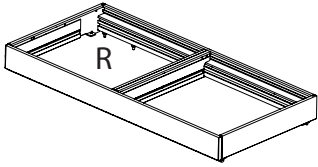

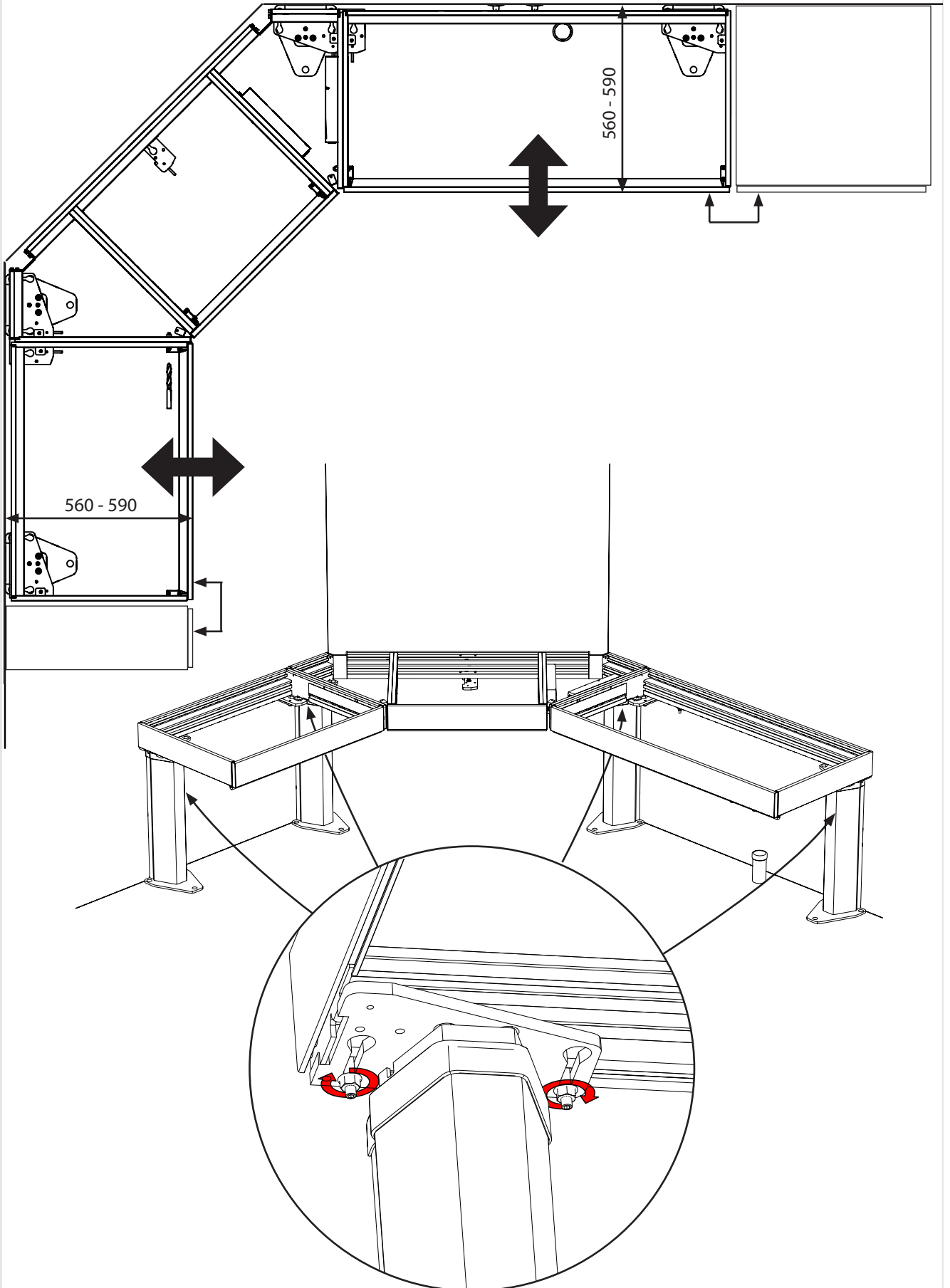

8

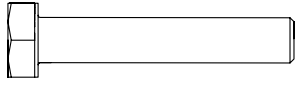

2x M8X45



2x M8



10 mm

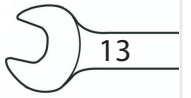

13

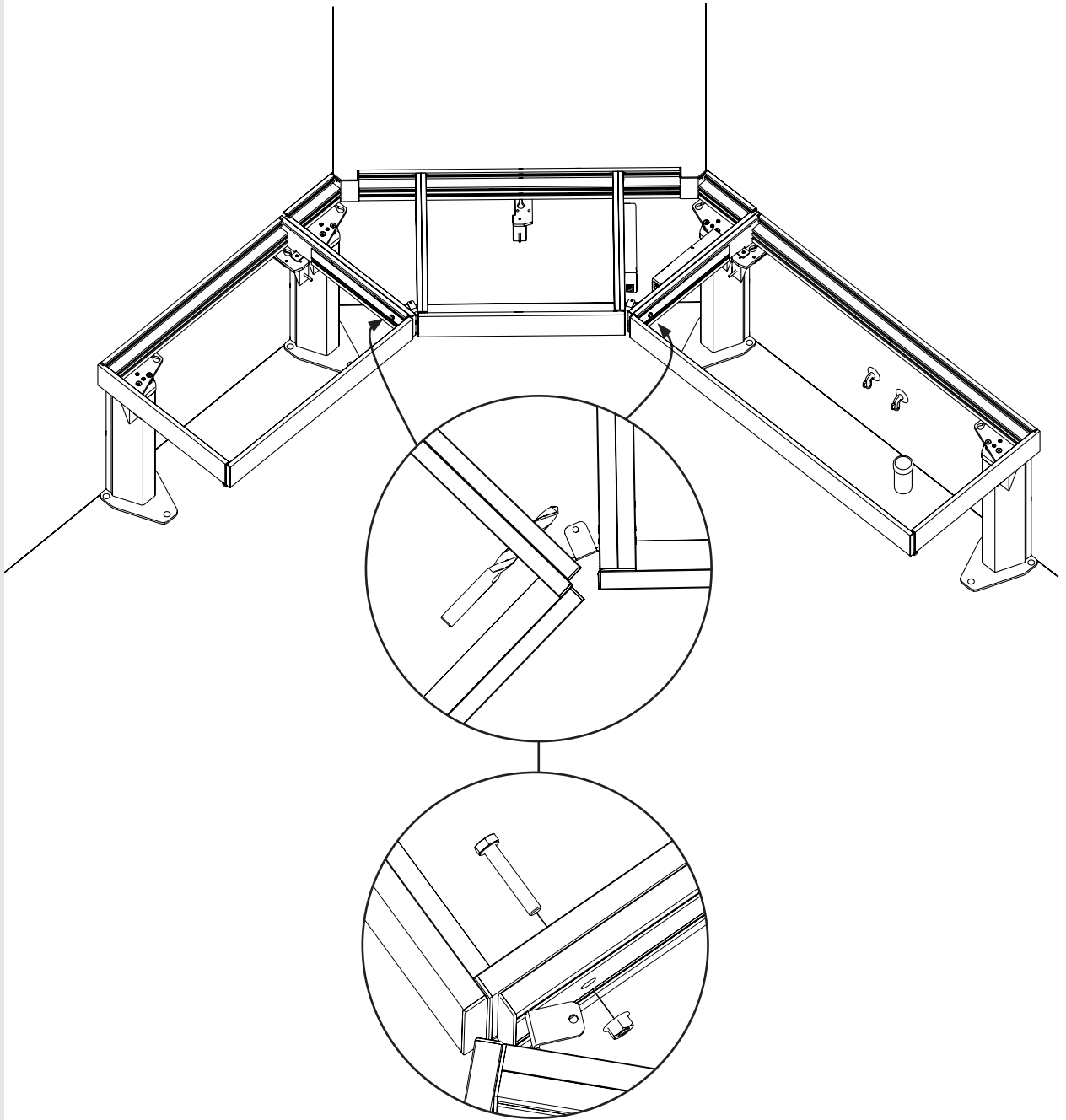

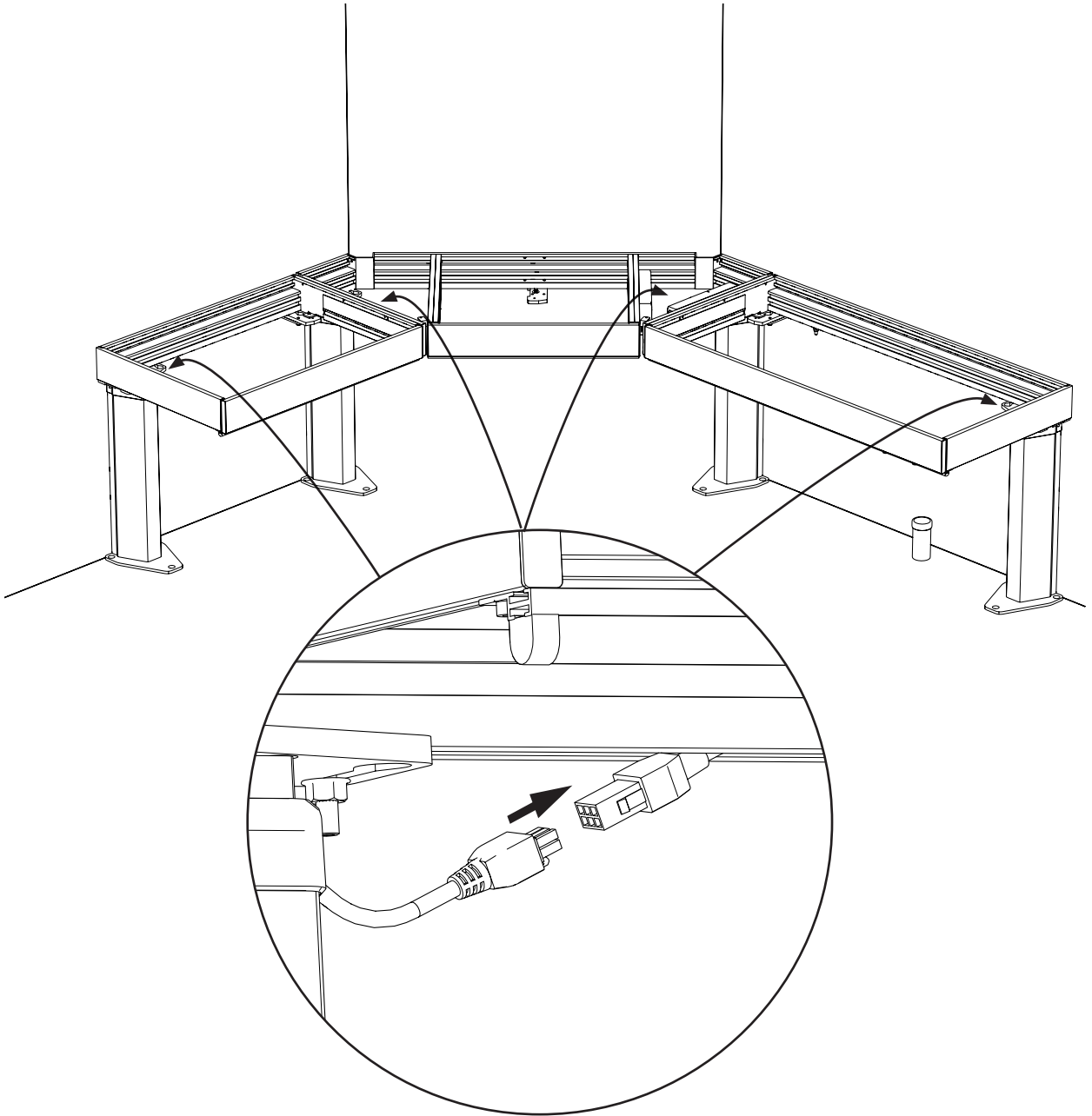

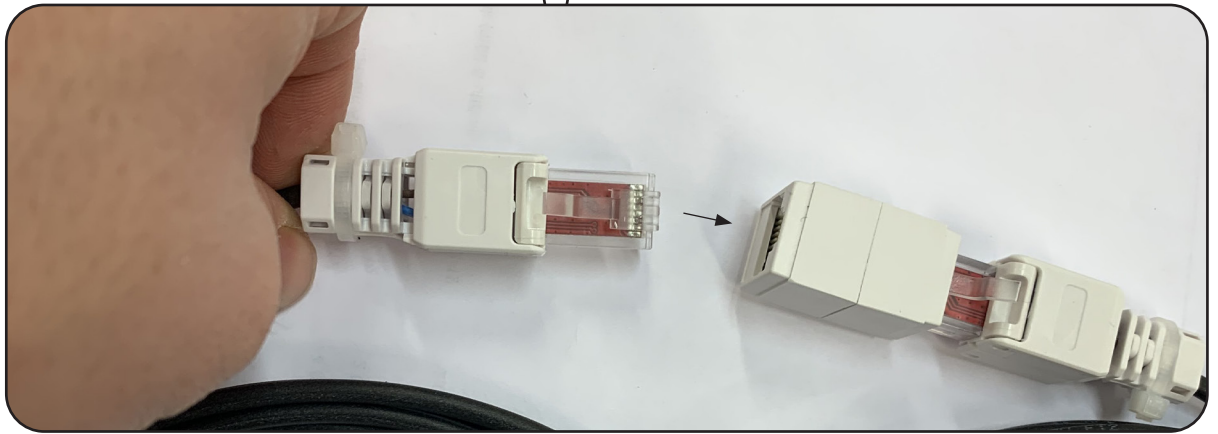
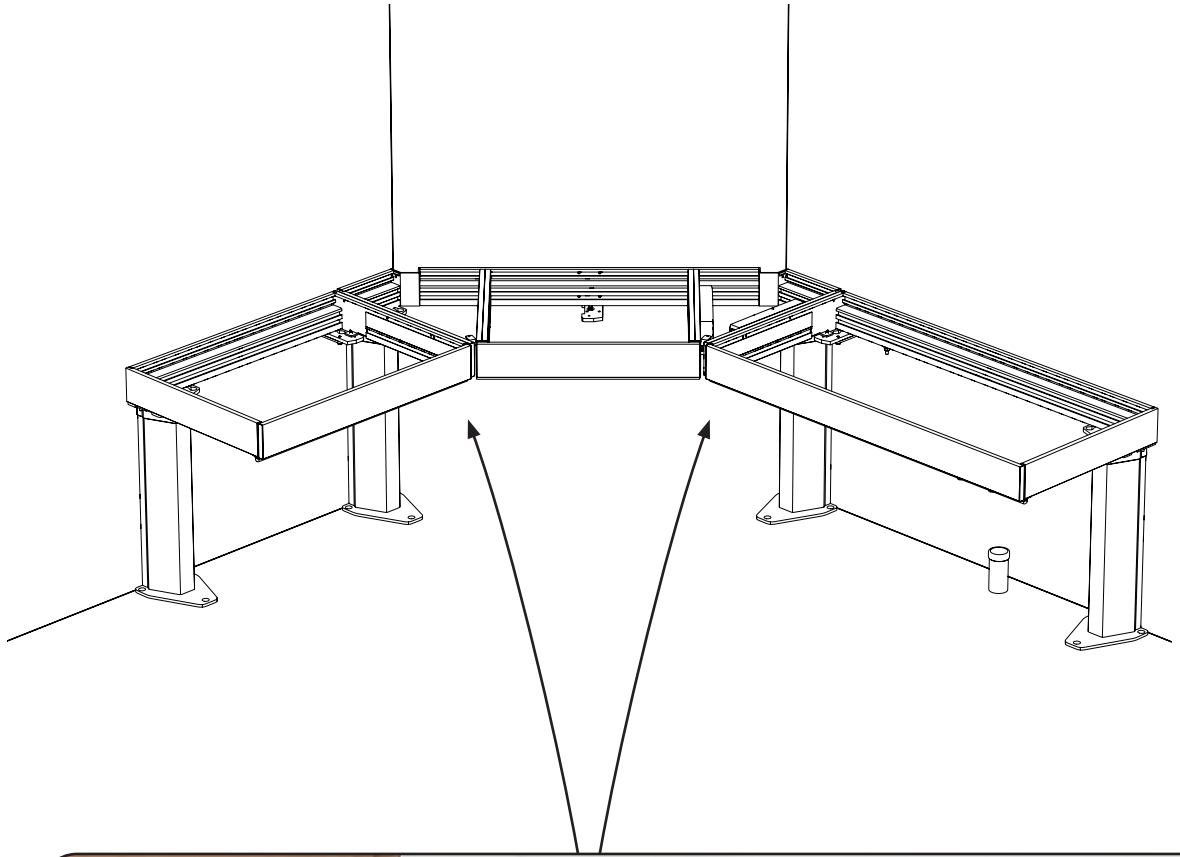

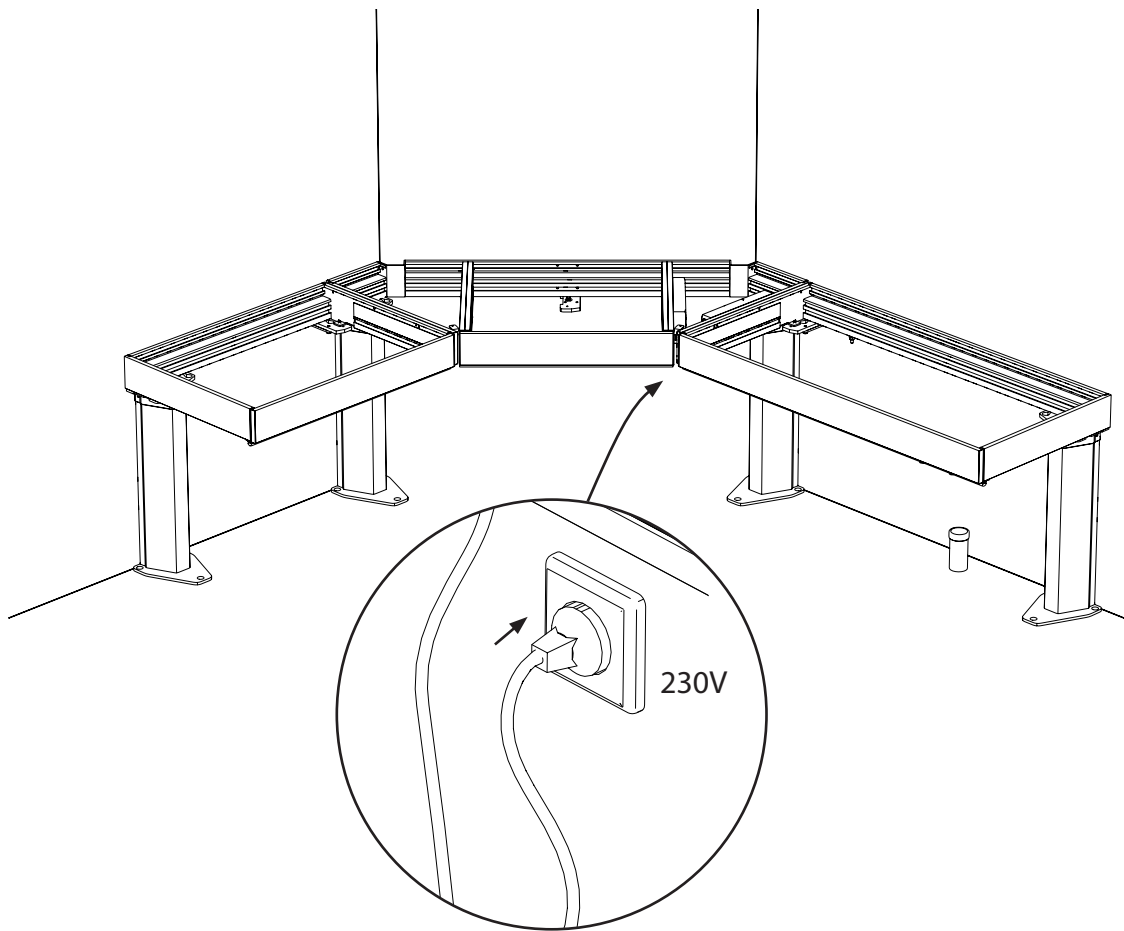



Träfront / wooden front / Holzfront

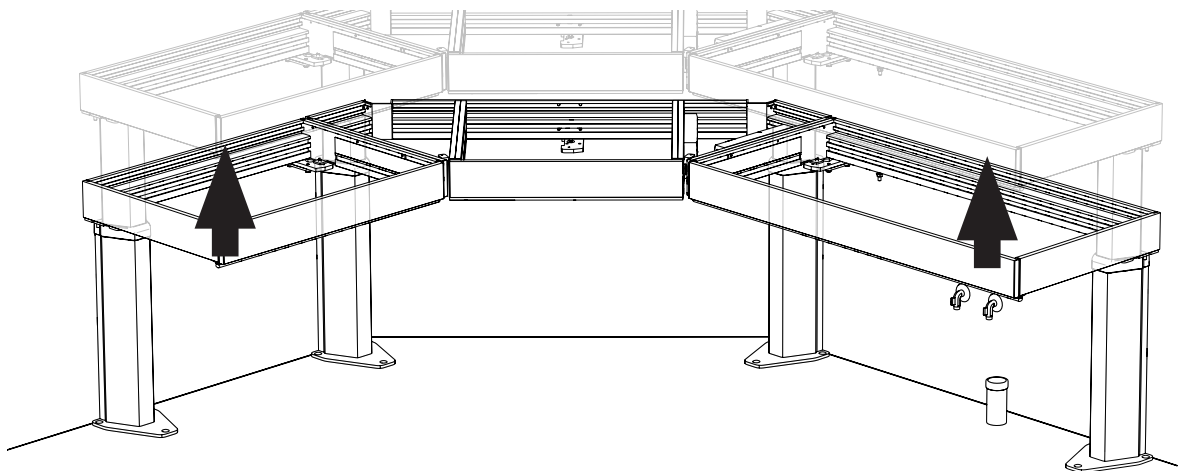
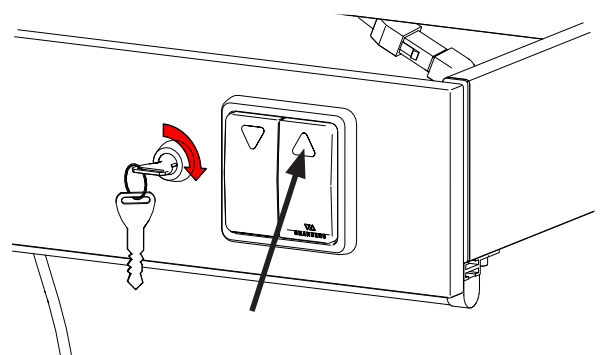
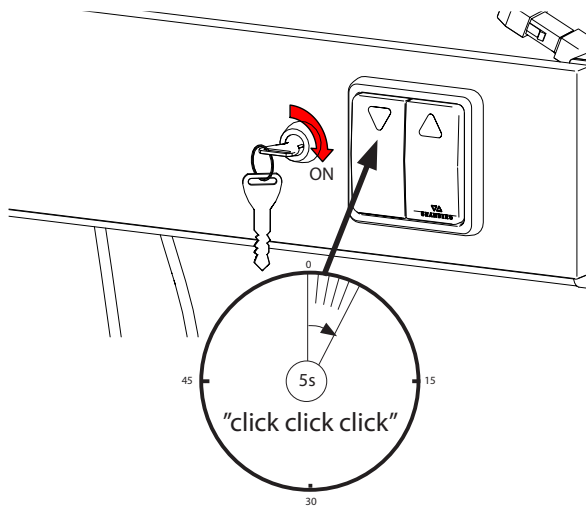
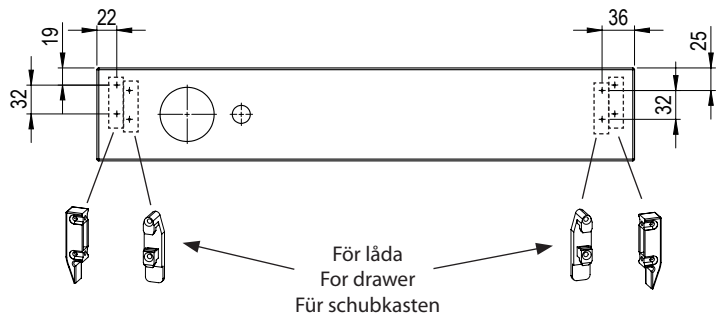
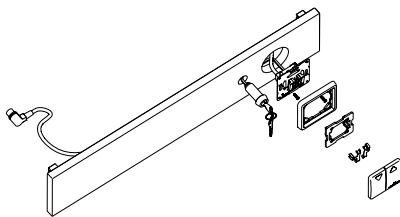
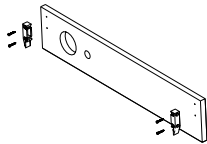
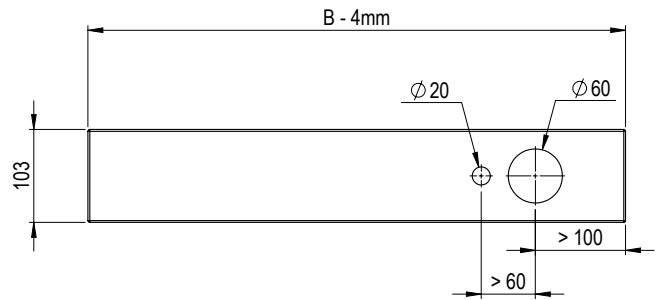
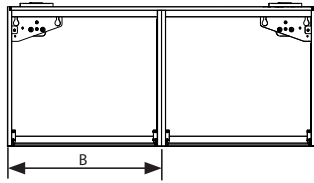

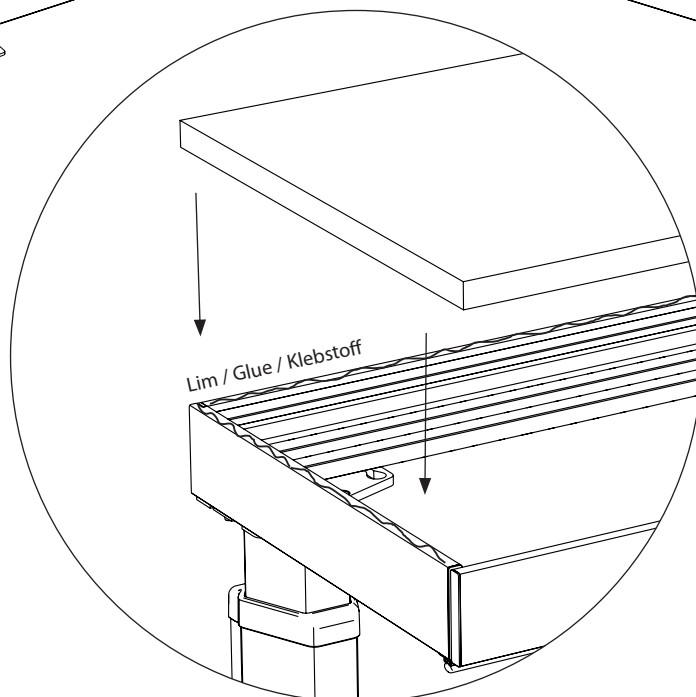
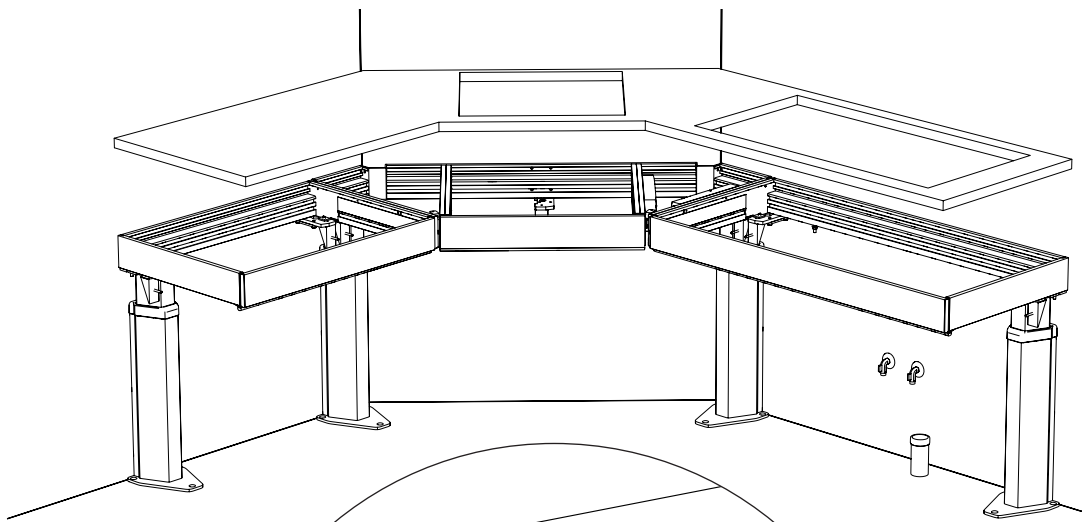
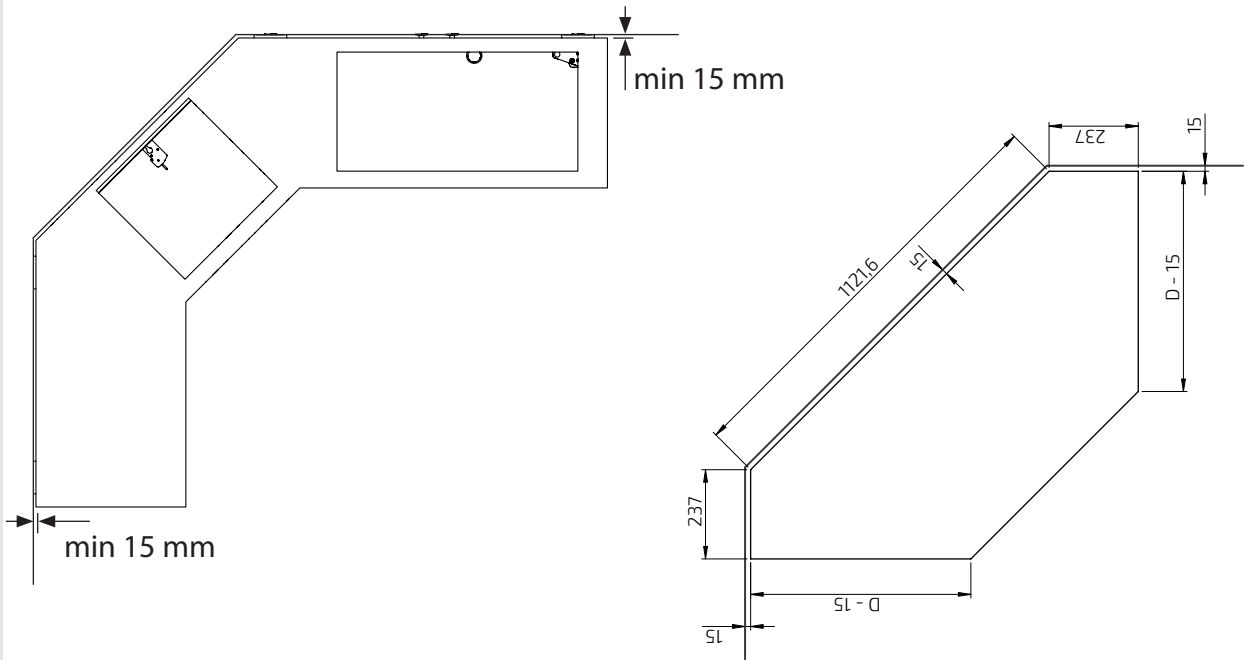

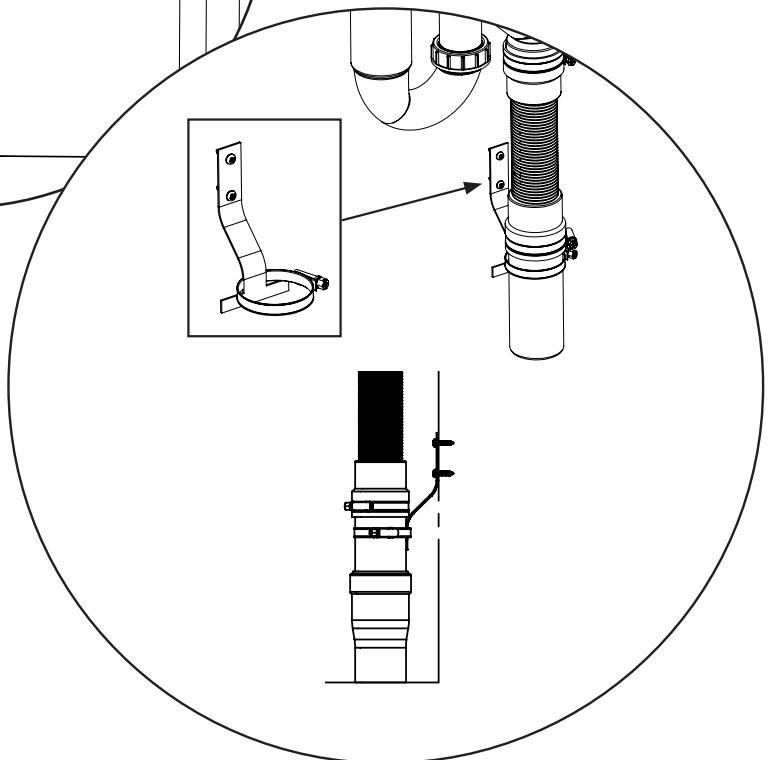
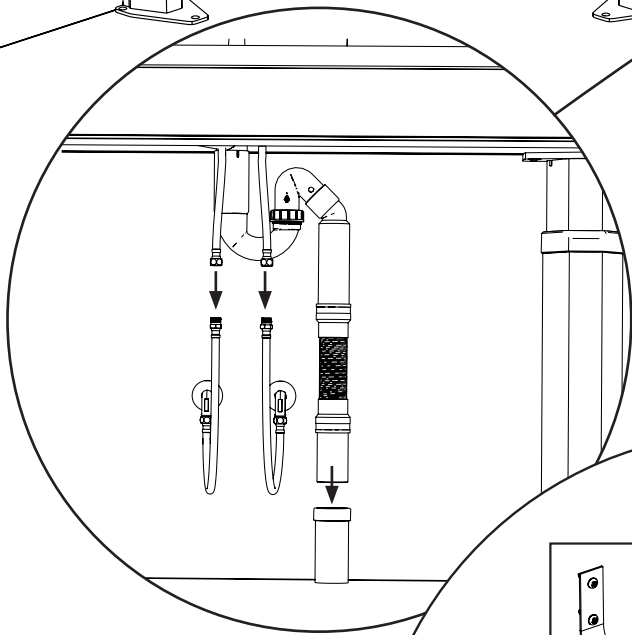
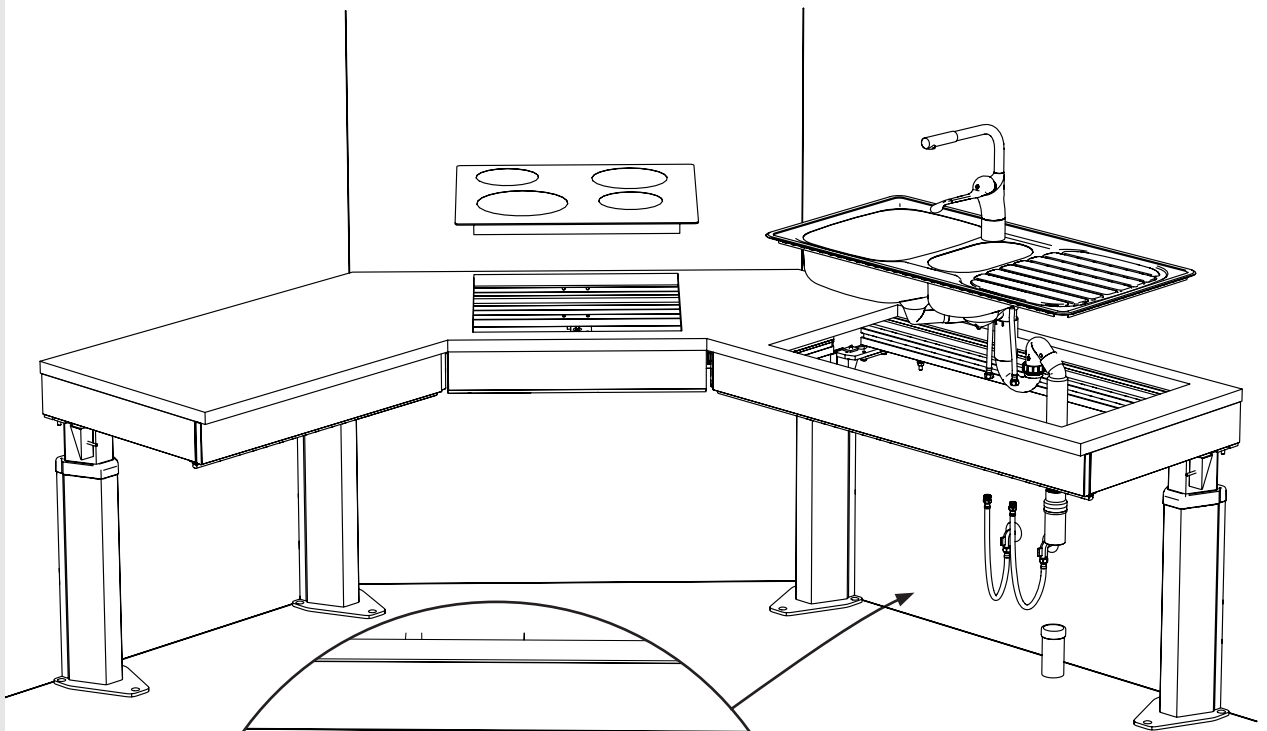

15

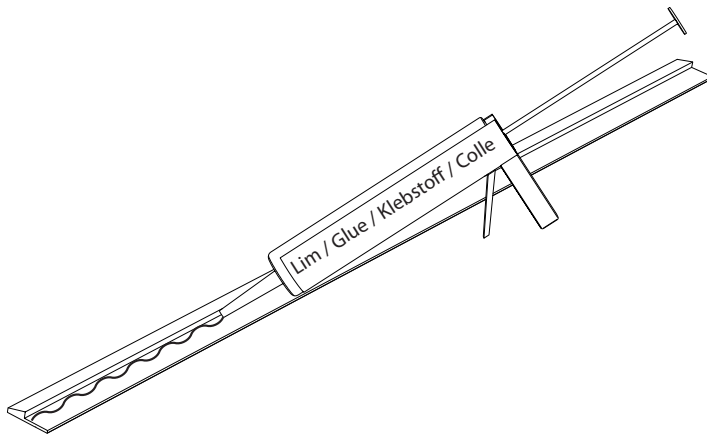
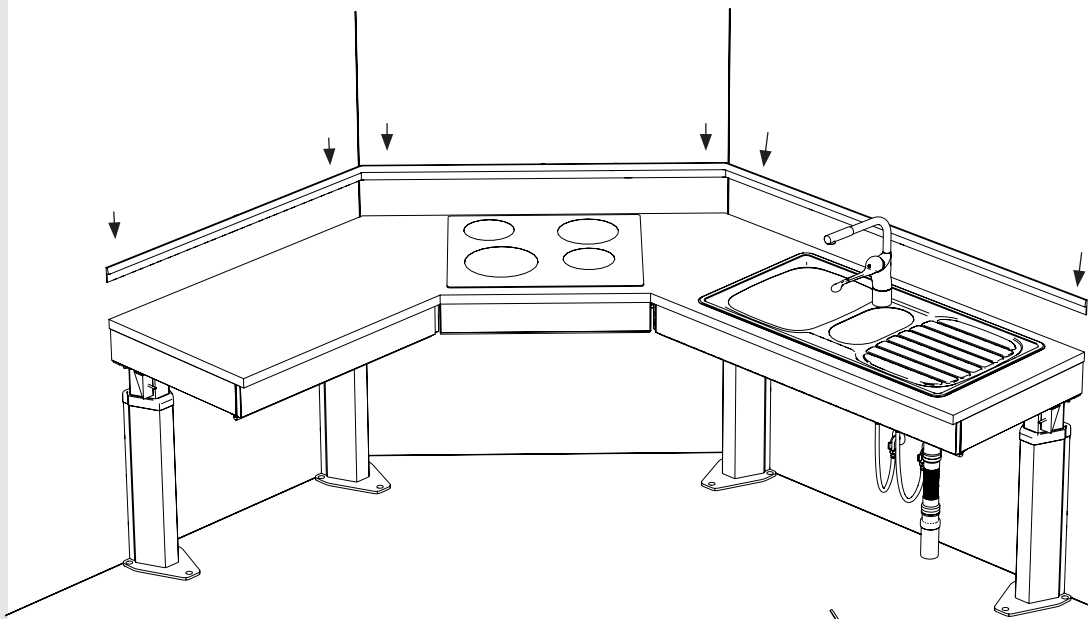
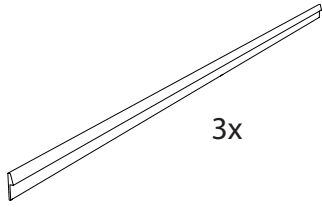

16

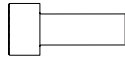
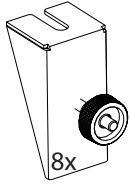

8x M6x12



HEX 4

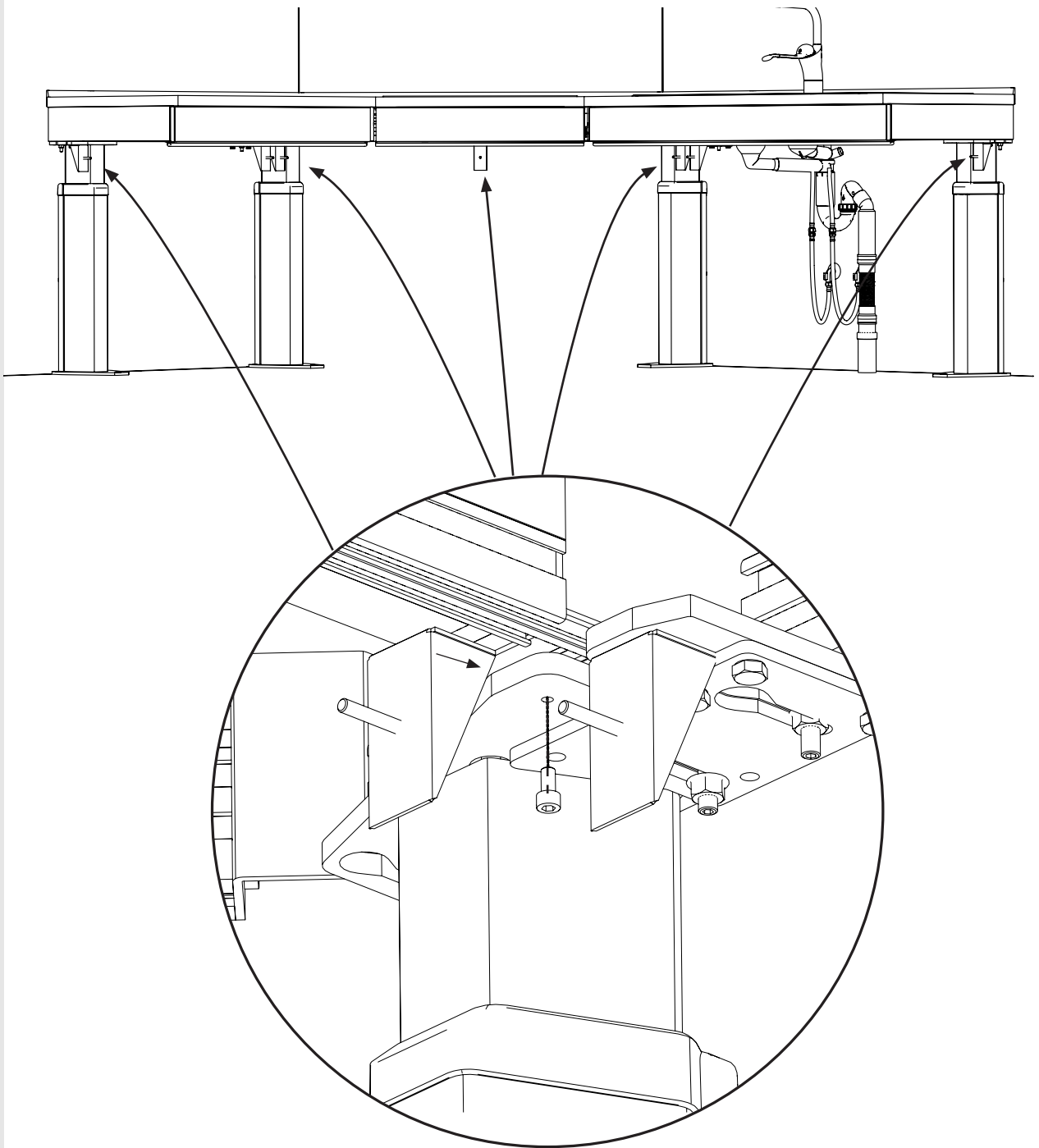

17

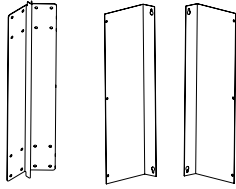

6x 3 x 16 mm



32x 3 x 12 mm



T10 PZ2

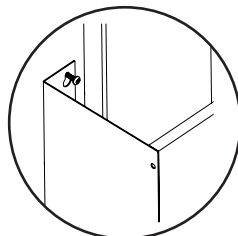
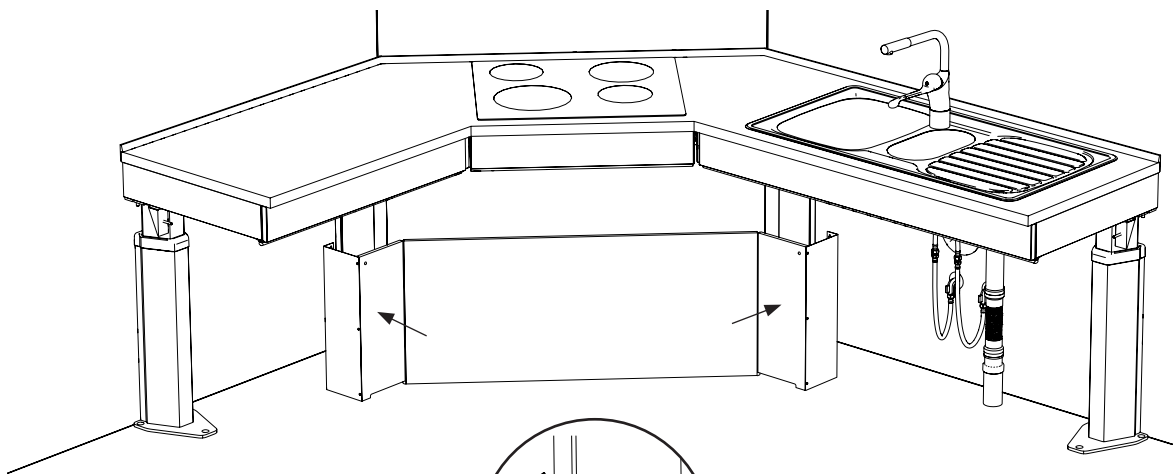
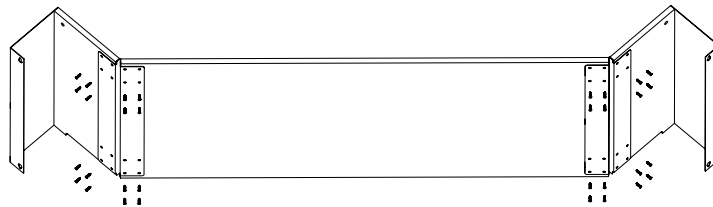
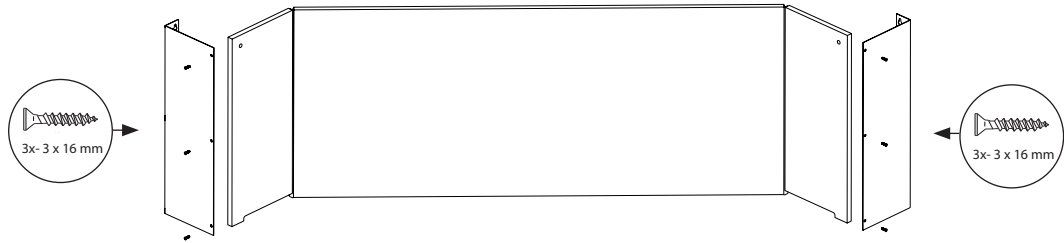
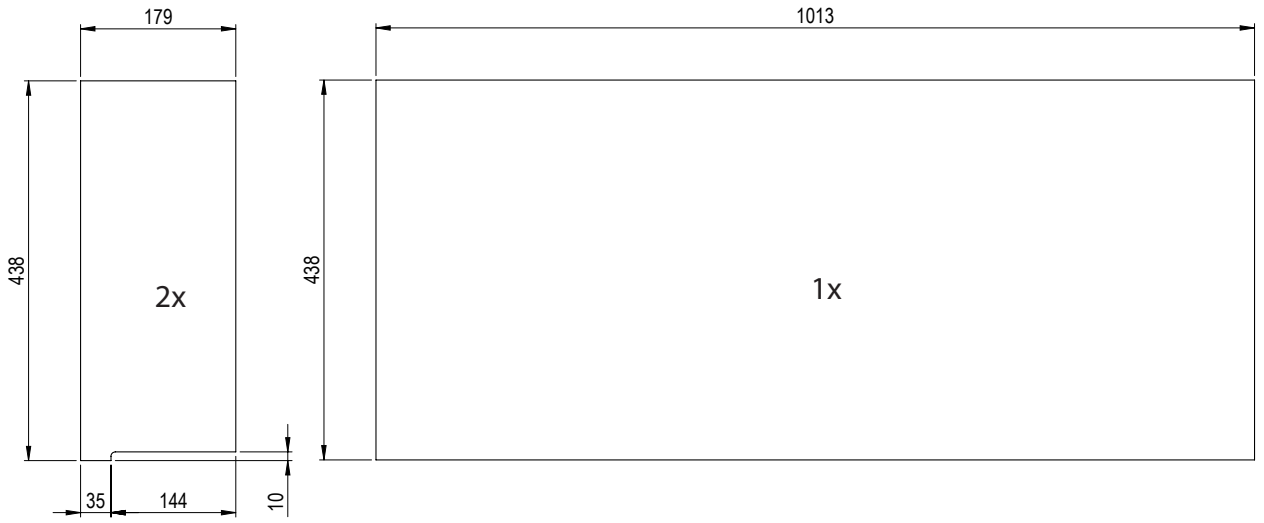

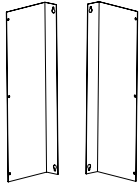

12x 3 x 16 mm



T10

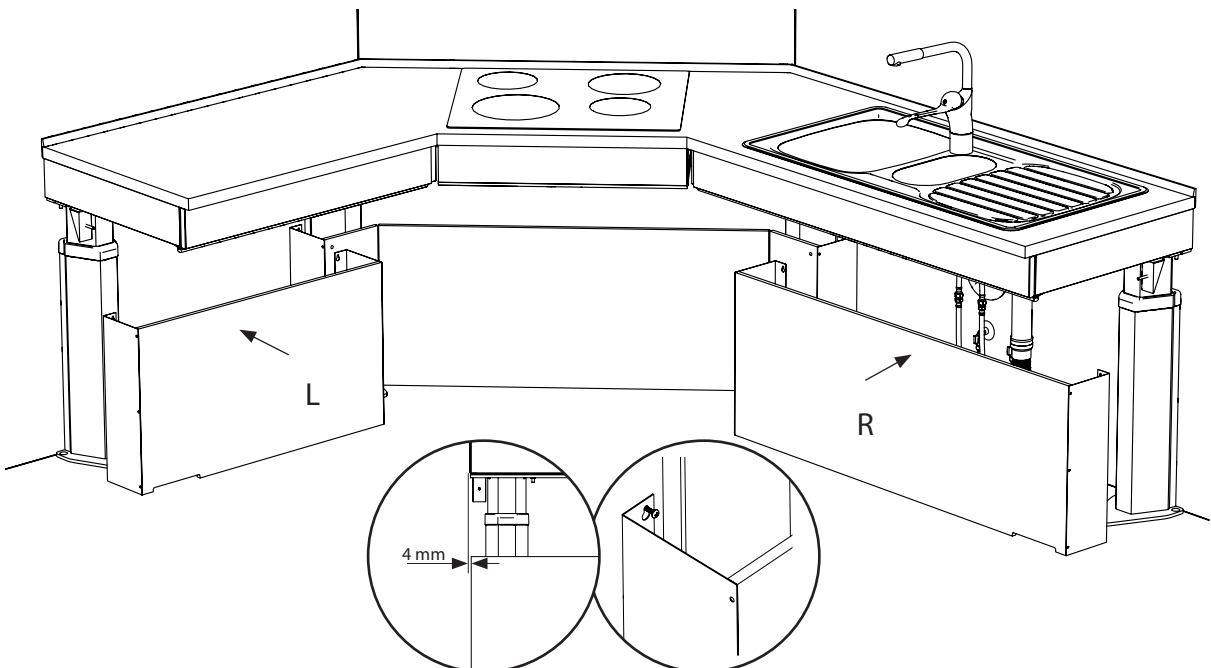
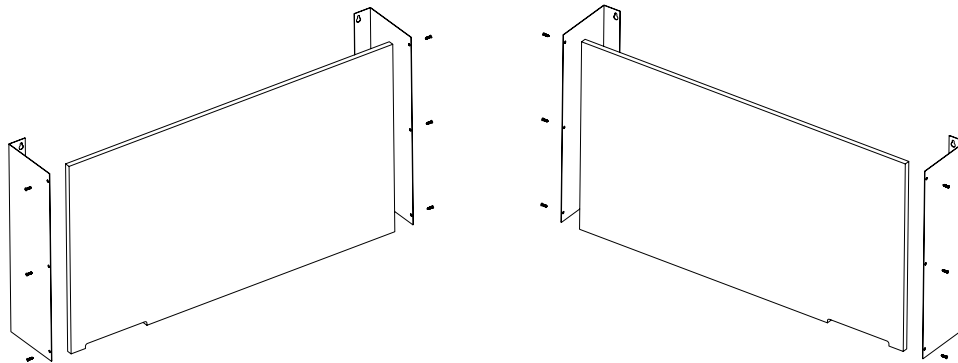
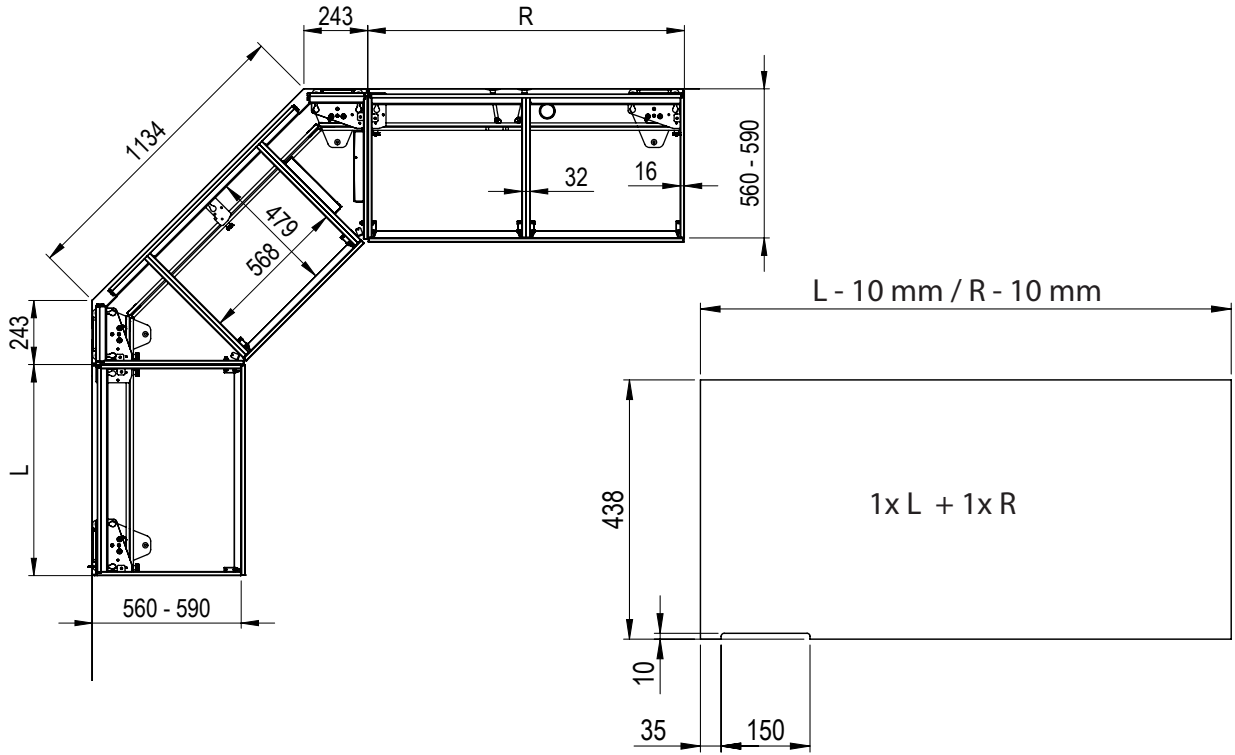

19

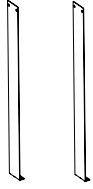

8x3x12 mm



T10

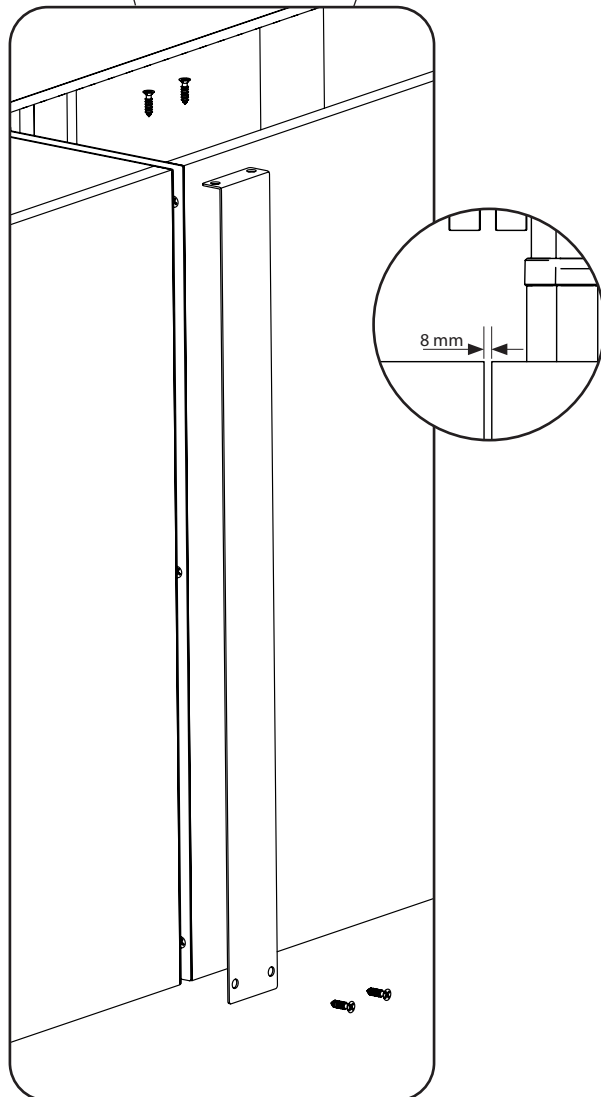
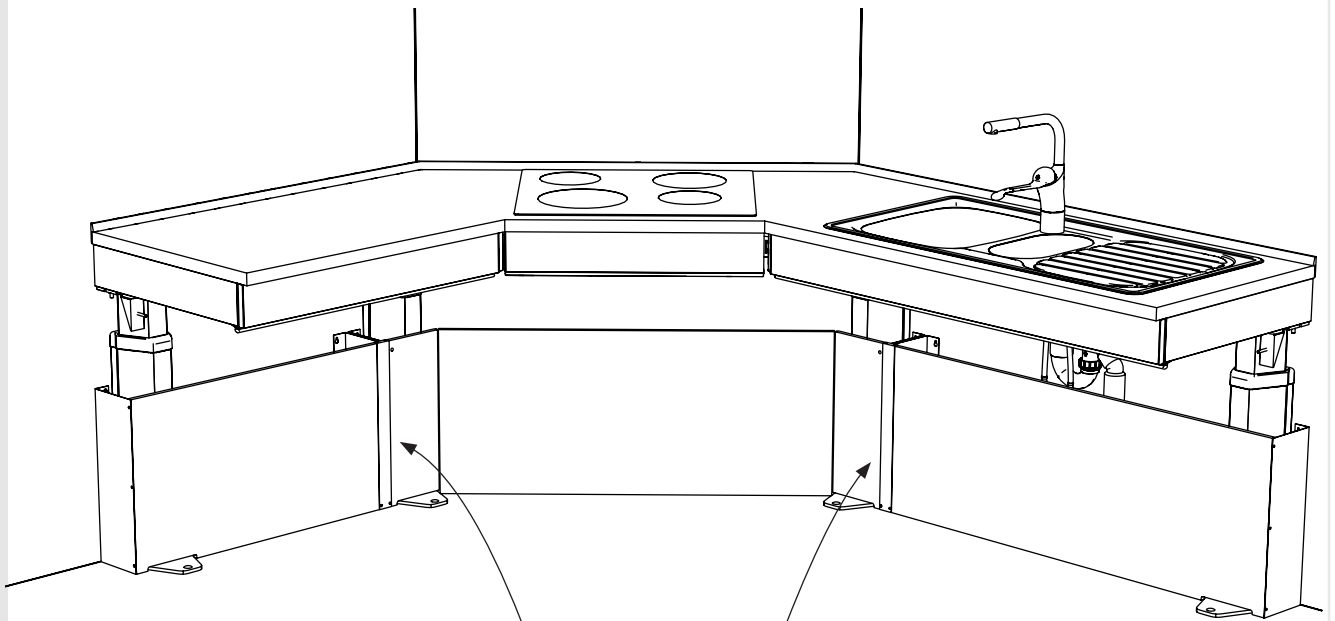



32x 3 x 12 mm



T10

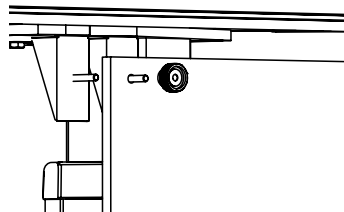
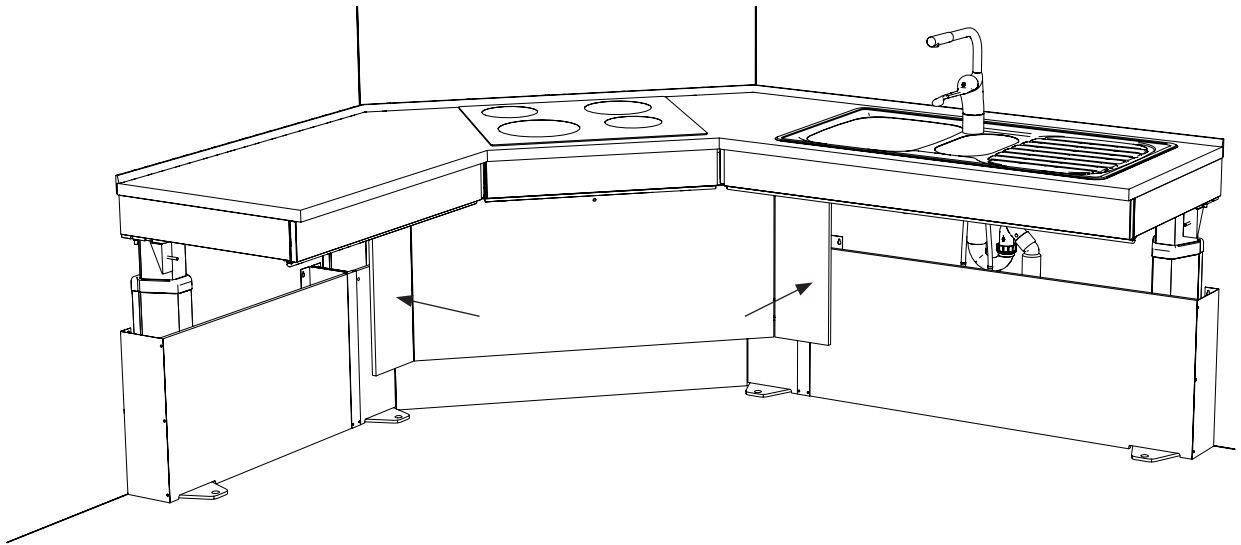
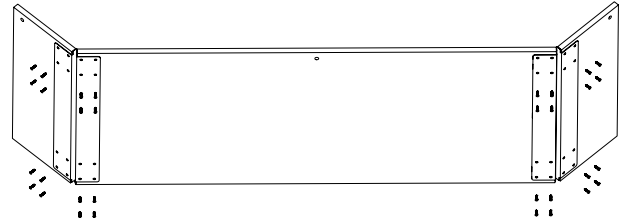
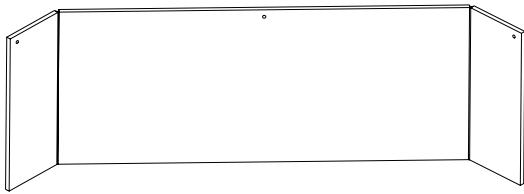
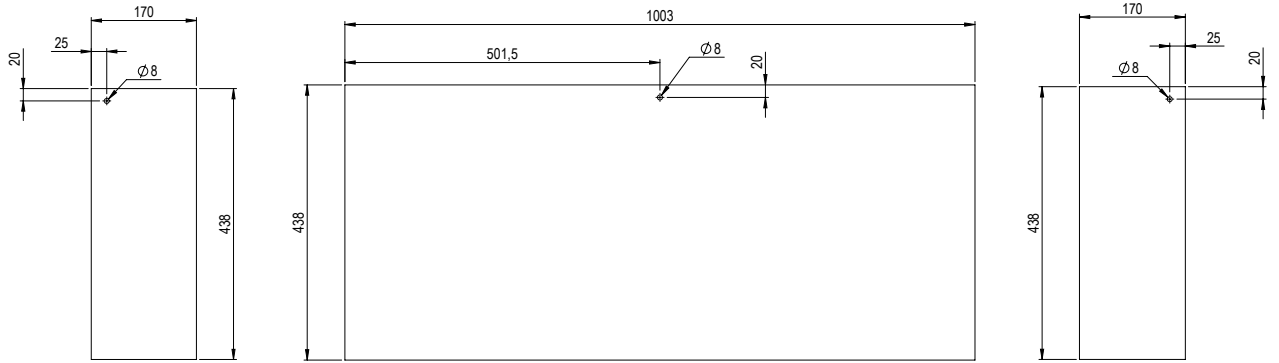

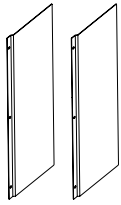

6x 3 x 16 mm



T10

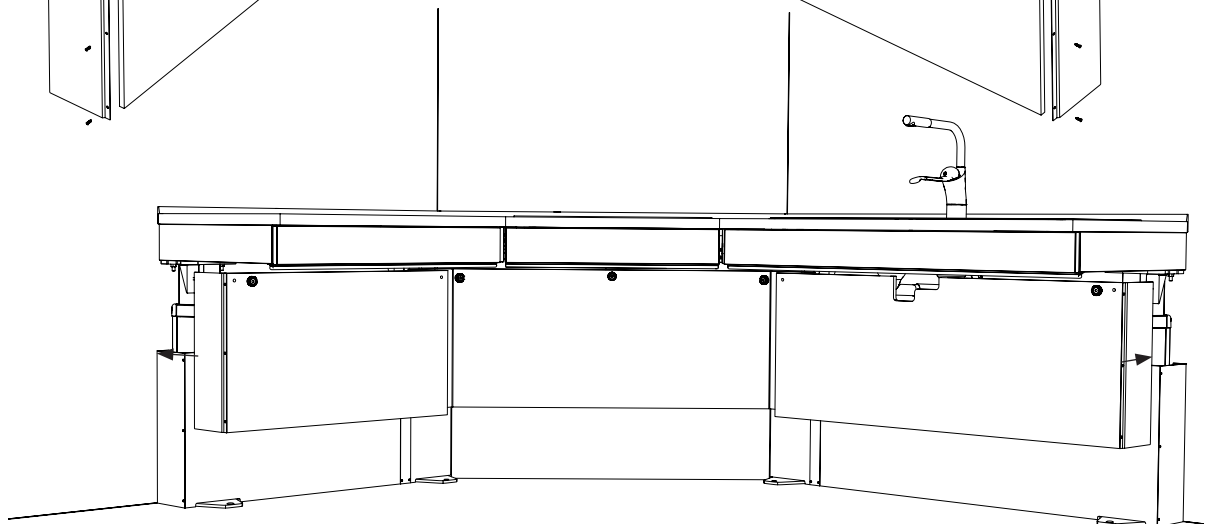
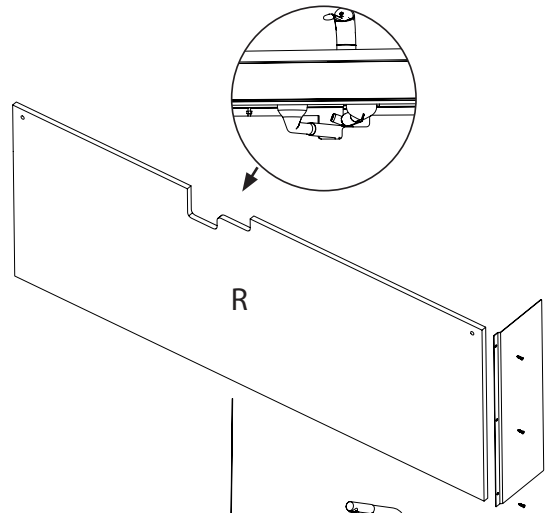
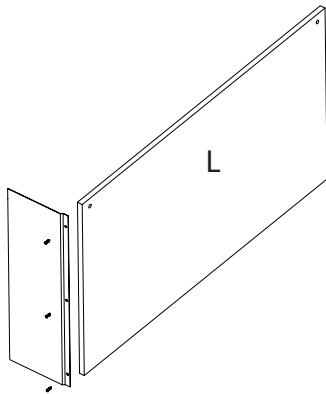
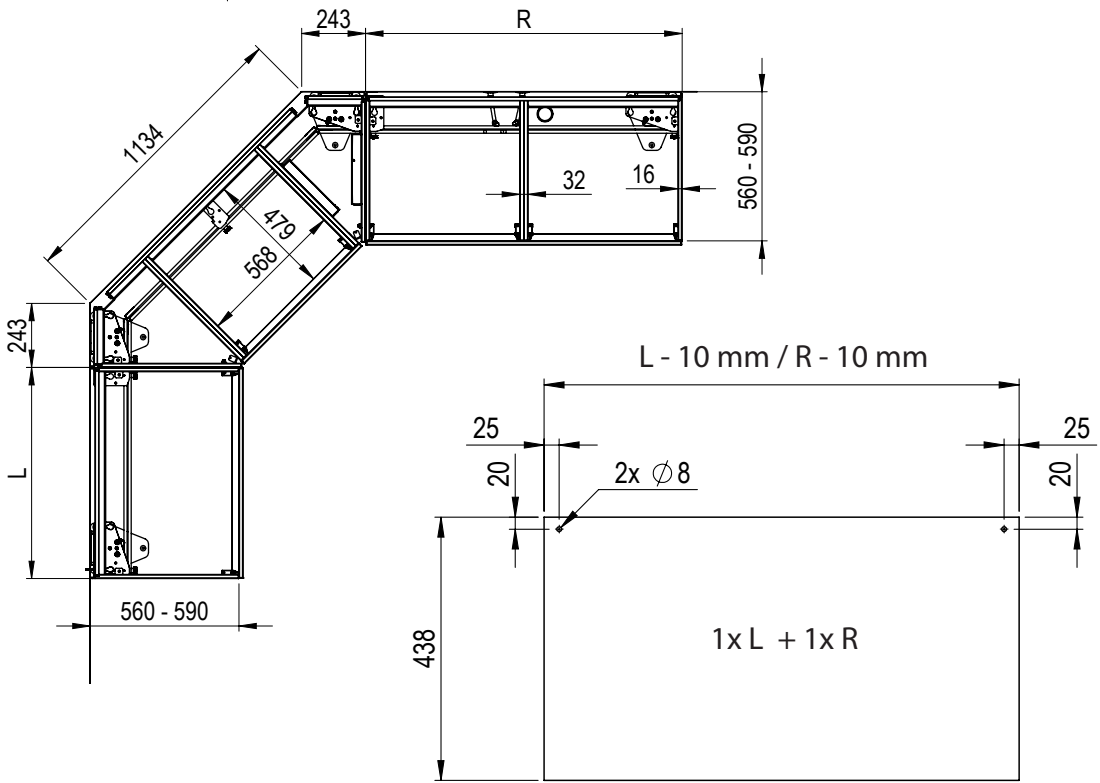

22

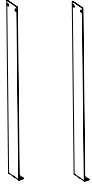

8x 3 x 12 mm



T10

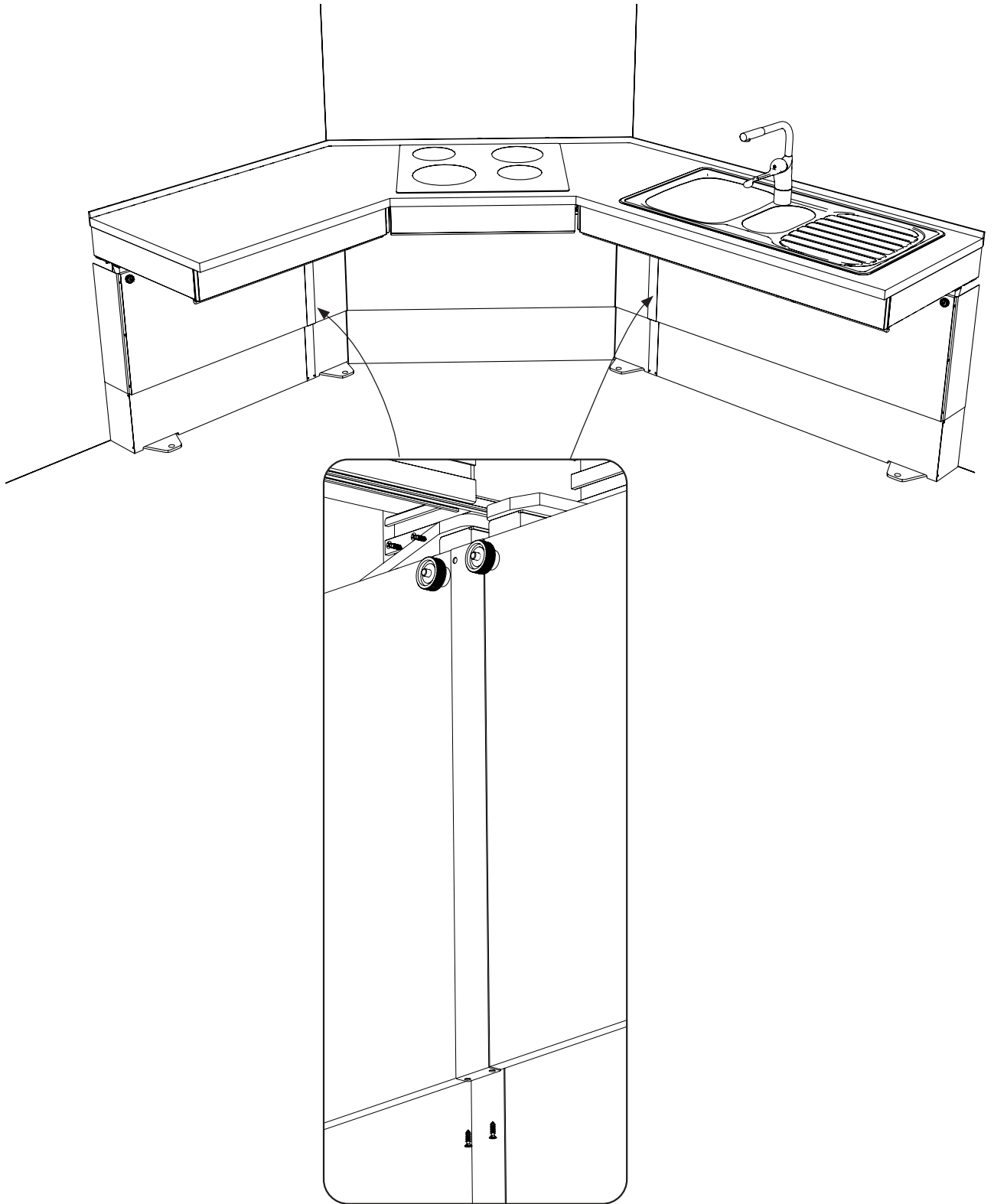

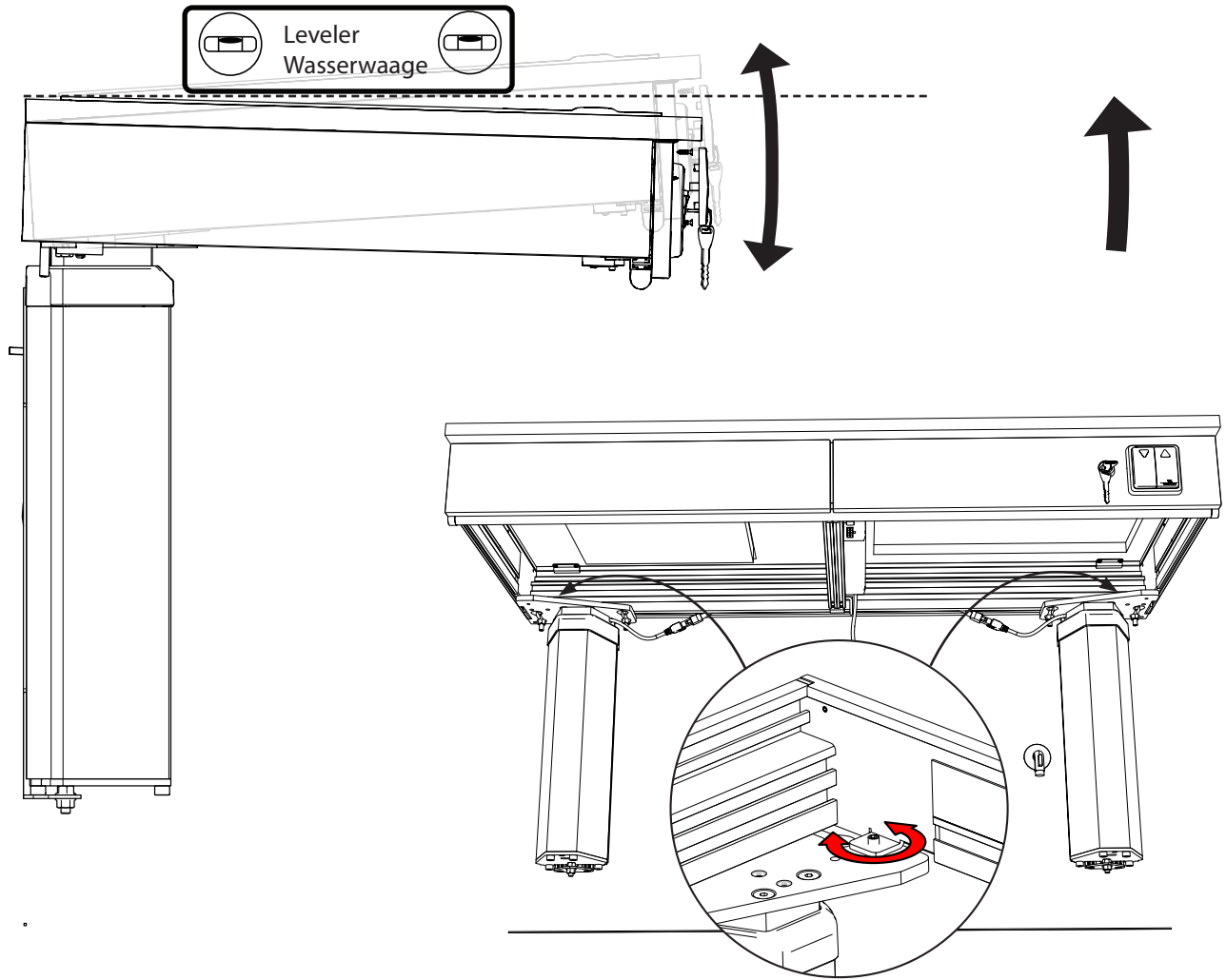

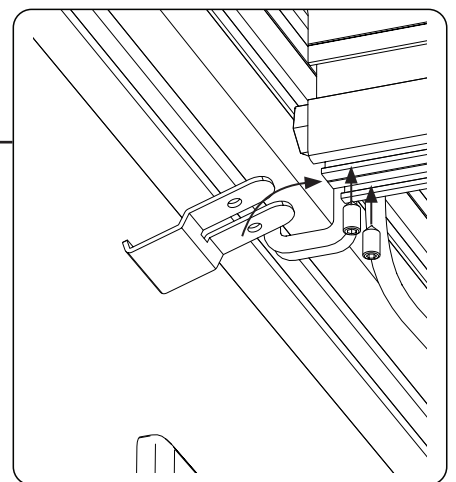
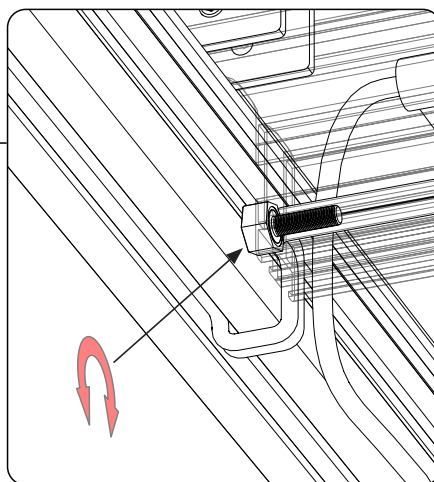
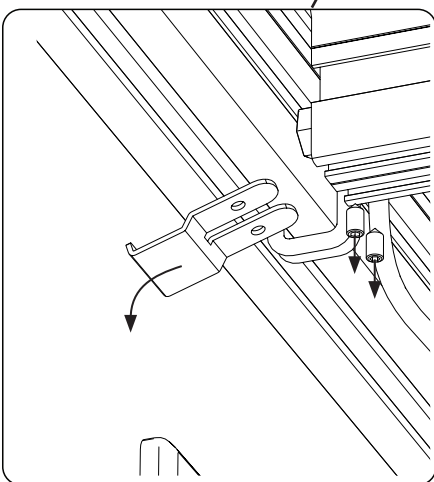
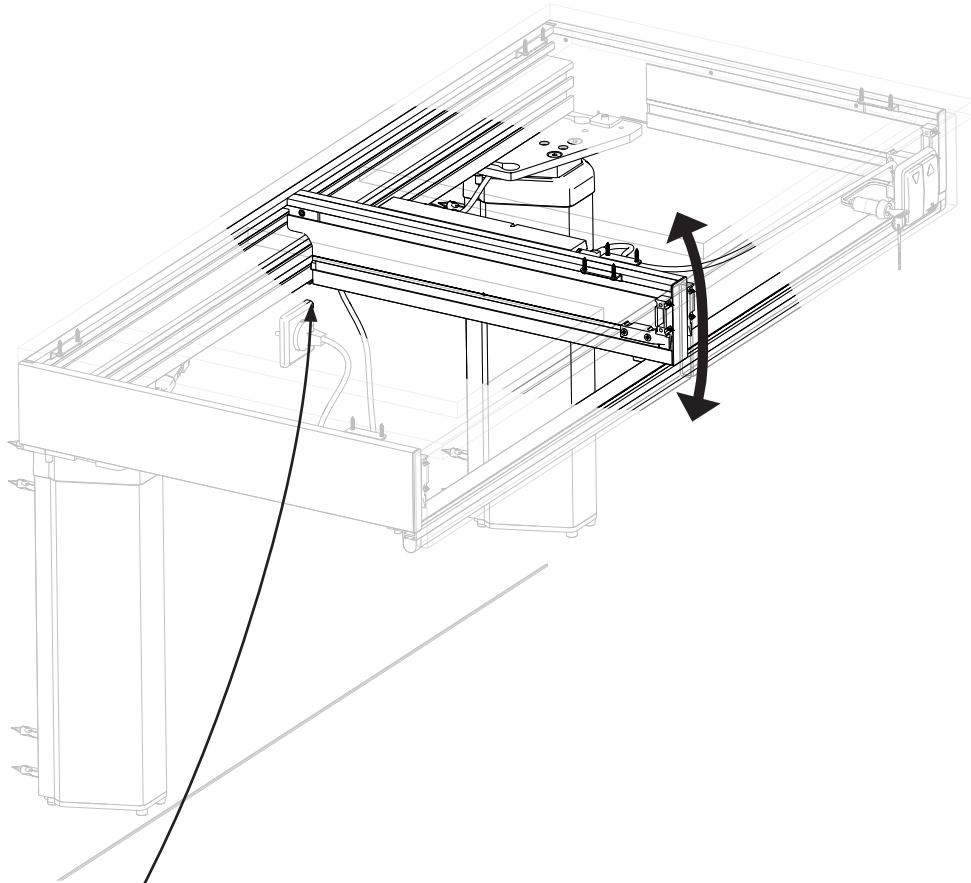

Funktionsprov

Efter installation ska komplett funktionsprov:

- * Provkör lyftenheten upp och ner hela vägen till respektive ändläge. Kontrollera att lyften löper fritt utan hinder, klämrisker och missljud. Kontrollera att den står kvar i nedre respektive övre läge.
- * Kontrollera att inga kablar kommer i kläm och att de är fixerade.
- * Kör lyftaren nedåt och funktionstesta klämlisten runt hela ramen . Tryck på den vid körning nedåt. Lyften ska stanna omedelbart och vända uppåt för att frige utrymme när ett klämskydd aktiveras.

Functional tests

Complete functional tests should be carried out after installation:

- * Test run the lift unit up and down all the way to each end position. Make sure that the lift runs freely without obstacles, risk of pinching and noise. Make sure it remains at each end position.
- * Make sure that no cables get pinched and that they are fixed.
- * Lower the lift and test the function of the anti-pinch strip all around the frame. Press on it while lowering. The lift should stop immediately and rise to free up space when anti-pinch protection is activated.

Funktionstest

Nach der Montage muss eine vollständige Funktionsprüfung durchgeführt werden:

- * Fahren Sie den Lift probeweise bis in die jeweilige Endposition auf und ab. Überprüfen Sie, das der Lift ohne Störgeräusche und ohne Klemmgefahren läuft. Der Lift muss in den jeweiligen Endpositionen stehen bleiben.
- * Stellen Sie sicher, das keine Kabel oder Schläuche gequetscht werden und das diese sicher befestigt sind.
- * Fahren Sie den Lift abwärts um die Funktion der Klemmschutzleiste zu testen. Üben Sie während der Fahrt druck auf die Klemmschutzleiste aus. Der Lift muss sofort stoppen und eine Gegenbewegung auslösen.

Innan driftsättning - Läs användarmanual

Endast behöriga personer får använda denna produkt!
Behörighet innebär skyldighet att ta del av, samt följa instruktionerna.
Det är mycket viktigt att ni läser och förstår användarmanualen innan driftsättning.
Användarmanualen medföljer denna installationsanvisning som separat häfte.

Samtliga handlingar som medföljer produkten ska finnas tillgänglig för berörd personal, förvaras på skyddad plats och ska åtfölja produkten, om den övergår till annan installationsplats eller annan bostadsägare.
Korrekt användning, manövrering, inspektioner och underhåll är avgörande för effektivt och säkert arbete.

Om ni har frågor - kontakta er leverantör.

Before you use the device - Read the users manual

Only authorized persons may use the this product!
Authorization means obligation to read and follow the instructions.
It is very important that you read and understands the users manual before you use the device.
The user manual is attached as a separate booklet.

All of the accompanying documents shall be available for all concerned persons, be kept in a protected place and shall follow the product, if it is moved to another installation site or another house or apartment owner.
Correct use, operation, inspections and maintenance are decisive for efficient and safe work.

If you have any questions - contact your supplier.

Vor der Nutzung des Geräts lesen Sie bitte das Benutzerhandbuch

Dieses Produkt darf nur von autorisierten Personen bedient werden!
Autorisiert bedeutet die Verpflichtung, die Anweisungen zu lesen und zu befolgen.
Es ist sehr wichtig, dass Sie das Benutzerhandbuch gelesen und verstanden haben, bevor Sie das Gerät verwenden.
Das Benutzerhandbuch ist als separate Broschüre beigefügt.

Sämtliche Begleitdokumente müssen für alle involvierten Personen verfügbar sein, an einem geschützten Ort aufbewahrt werden und dem Produkt folgen, wenn es an einen anderen Installationsort oder in eine andere Wohnung wechselt.
Die ordnungsgemäße Verwendung, Bedienung, als auch die Wartungen und Inspektionen sind entscheidend für ein sicheres und effizientes Arbeiten.

Bei Fragen wenden Sie sich bitte an Ihren Händler.

Forhandler i Norge:

ASTEC AS
Kapellveien 18, 1410 Kolbotn
22 72 23 55 • astec.no



GRANBERG



Granberg Interior AB
Importgatan 30 602 28, Norrköping
Tel: 011-19 77 50
E-mail: info@granberg.se
Internet: www.granberg.se



Granberg Deutschland GmbH
Eggeweg 91, 33617 Bielefeld
Tel: +49 521 1439983
E-mail: info@granberg.de
Internet: www.granberg.de

